



MT / GST Turnstile Installation & Maintenance Instructions

Precautions:

Read this installation guide in its entirety before installing the turnstiles. If there are any questions, call Alvarado at (909) 591-8431 or (800) 423-4143, Monday through Friday, 6:00 AM to 4:30 PM PST. Installers & Store Personnel must provide this document to the manager or person responsible for the maintenance of the Turnstile(s).



WARNING

Installers & Store Personnel:

- The product is designed for indoor use only.
- Use only skilled individuals to install and service the turnstile.
- The turnstile is not a toy. Do not allow children to play on or near the turnstile.
- Follow a proper maintenance schedule using skilled individuals.
- Do not modify or alter the turnstile.
- Do not use non-Alvarado parts.
- Do not operate the turnstile if it has been damaged in any manner. Have the unit repaired or adjusted by a skilled service person before use.

Models Supported:

TABLE 1 – Turnstiles Models; including a Short Product Description.

| Model Number | Short Product Description |
|--------------|--|
| MTA01-001 | MT Straight Arm Turnstile Head with Clockwise Rotation, Turnstile Post, Connecting Post/Rail & Curved Yoke – Full Assembly – Bright Finish. |
| GST01-001 | Greater Security Turnstile Head with Clockwise Rotation, Turnstile Post, Connecting Post/Rail with Over Arm Barrier & Curved Yoke – Full Assembly – Bright Finish. |

Materials & Tools:

TABLE 2 – Turnstiles Models with a Description of Materials Enclosed & Tools Required.

| Turnstiles Model & Materials Enclosed | | Tools Required |
|--|---|---|
| MT | GST | <ul style="list-style-type: none"> ▪ Hammer Drill & Shop Vac ▪ 5/8" Concrete Drill Bits (1.0" Zenith Post) ▪ Ratchet w/ a 9/16" Socket (15/16 Zenith Post) ▪ 3/16" Allen Wrench ▪ Slotted Head Screw Driver ▪ Rubber Mallet |
| <ul style="list-style-type: none"> ▪ Turnstile Head (MT) ▪ Turnstile Post ▪ OV Rail ▪ OV Post ▪ Yoke ▪ Yoke Post | <ul style="list-style-type: none"> ▪ Turnstile Head (GST) ▪ Turnstile Post ▪ OV Rail ▪ OV Post ▪ OV Arm ▪ Yoke ▪ Yoke Post | |
| | | <p style="text-align: center;">Materials Required</p> <ul style="list-style-type: none"> ▪ (3) SB-14 4-Way Anchor Packages |

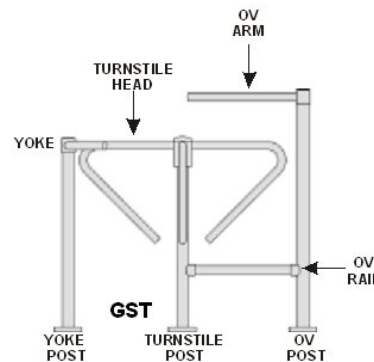
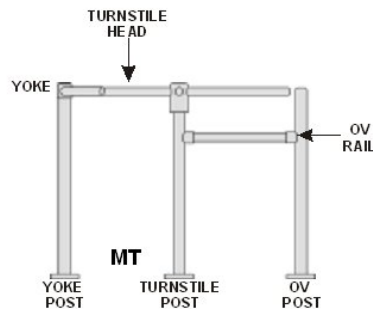

NOTE

The product is ready for installation on level concrete assuming that no modifications are made to the product.

Installation Instructions:

1. Verify the Turnstiles Model (TABLE 1) and snap a chalk line on the floor in the desired location(s) of the Post(s) to determine the proper centerlines of the Post(s). A tile line may be substituted for the chalk line. Allow a minimum distance of 22.5" (MT/GST) from the center of the Turnstile Post to the center of the Yoke Post. Be aware that if anymore than 3" is left between the Yoke Post and the Turnstile Arm, unwanted passage may be obtained.
2. Anchor the Posts and install the OV Rail according to the Vogue or Zenith Post installation instructions that are provided with this document. Ensure that all OV Rails OV Posts are straight and level. All bolts should be tightened to 20-ft/lbs. torque using a 9/16" socket. Secure OV Rails with the 1/4-20 x 1/4" set screw found in the base package.
3. Install the Turnstile Head onto the Turnstile Post by pressing it down over the Clutch Assembly while rotating it in the direction the turnstile will turn (to the left if counter-clockwise, or to the right if clockwise). Insert and tighten the retaining bolt. Make sure that the retaining ring is centered such that the Turnstile Head slides easily over the Clutch Assembly.

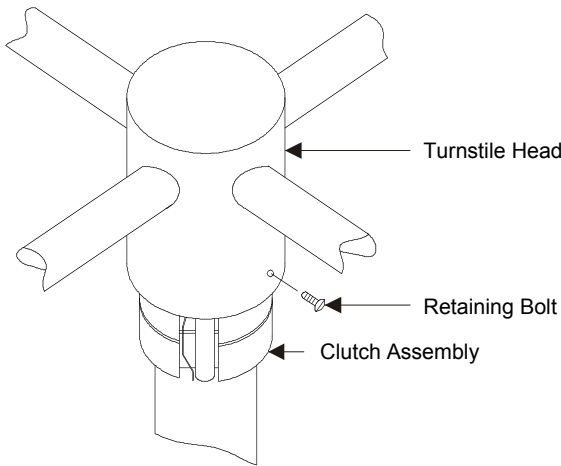

Installing the Turnstile Head.

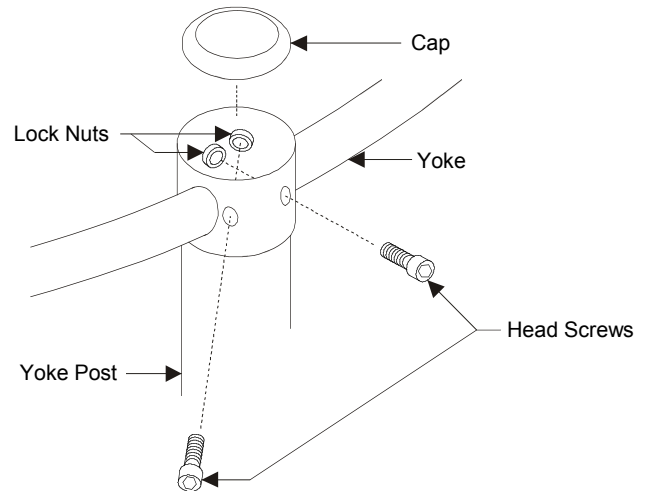

Installing the Yoke.

4. Insert and tighten the (2) Head Screws with Lock Nuts to attach the Yoke to the Yoke Post. If applicable insert the Cap to cover the top of the Yoke Post.



MAINTENANCE

Clean turnstiles with the correct type of cleaner for it's finish. Follow the instructions below depending on the finish:

Chrome:

Use a general all-purpose cleaner with a soft cloth.

Stainless Steel:

Use a Stainless Steel polish or cleaner. If a heavy scratch or mark is apparent, use a metal blend or finish pad.

Powder Coat:

Use a soft damp cloth. Any deep scratches or chips should be touched up to prevent rust. (If rust is untreated, rush will spread under the surface of the material.)

Replace any sharp, bent, or broken pieces IMMEDIATELY. Tighten any loose anchors.



WARRANTY

Alvarado Manufacturing Company warrants the equipment being sold against defects in material and workmanship, for the period of one (1) year from the date of purchase, providing recommended installation and maintenance procedures are followed. This warranty is void if damage was due to improper installation, maintenance, or use. The manufacturer will not be responsible for any shipping or labor charges incurred in the removal or replacement of defective parts.