

THIRD ANGLE PROJECTION

©ALVARADO

129601 Colony Street, Clarksville, IN 47129
 908.591.3403
 www.alvaradoag.com

TITLE: FMST

NAME	DATE	SIZE	DWG. NO.	REV
ROOM	7/22/2015	B	PEF-008	A
DRAWN				
CHECKED				
ENGR	RPL	7/22/2015	SCALE: 1:20	SHEET 1 OF 2

PROPRIETARY AND CONFIDENTIAL
 THE INFORMATION CONTAINED IN THIS DRAWING IS THE PROPERTY OF ALVARADO. REPRODUCTION OR TRANSMISSION IN ANY FORM OR BY ANY MEANS WITHOUT THE WRITTEN PERMISSION OF ALVARADO IS PROHIBITED.
 DO NOT SCALE DRAWING

NOTES:
 1. ALL DIMENSIONS ARE APPROXIMATE AND IN INCHES [mm].

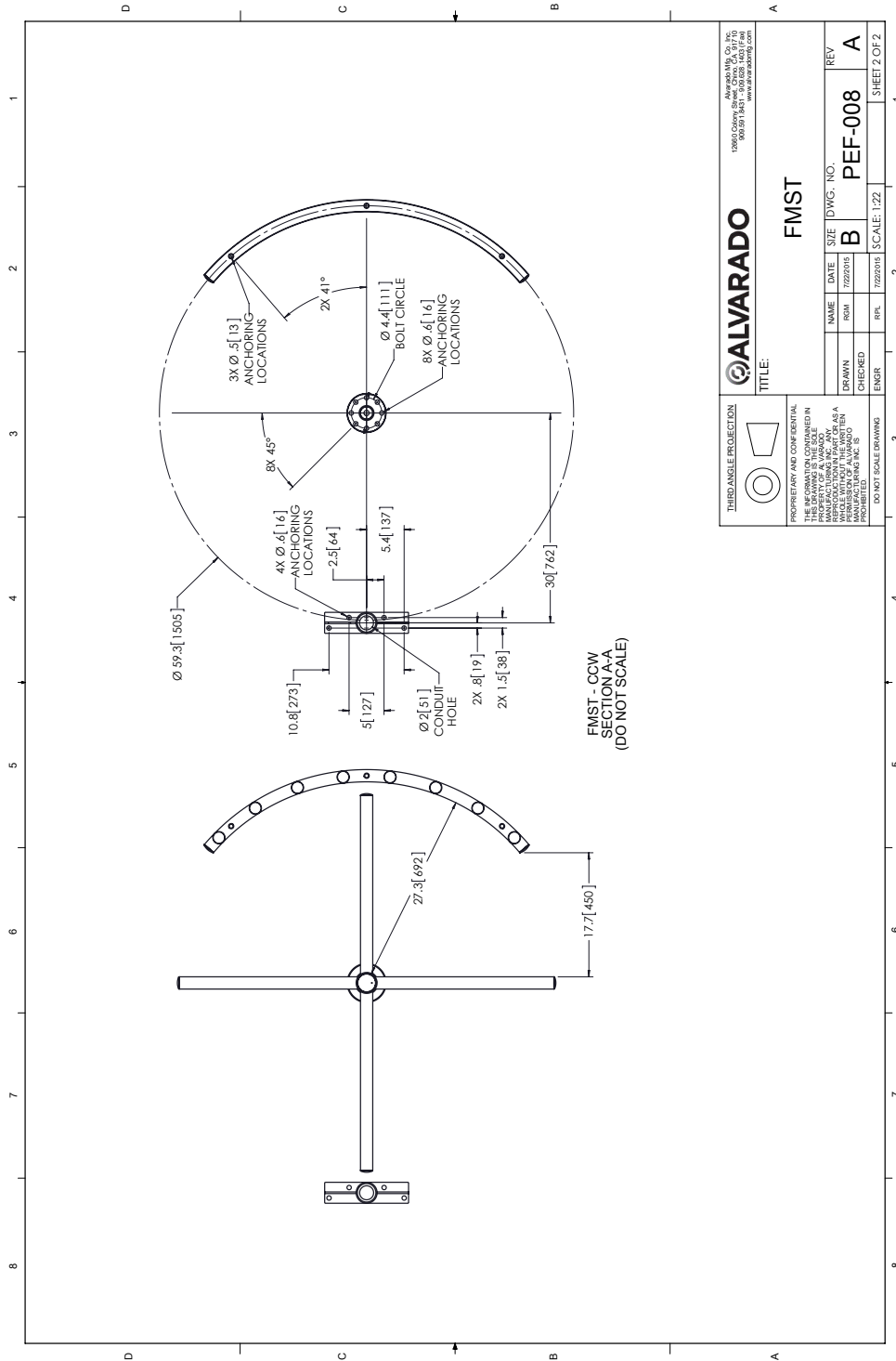

129603 Colony Street, Clarksville, IN 47129
900.591.3400
www.avantgarde.com

ALVARADO

TITLE: FMST

NAME	DATE	SIZE	DWG. NO.	REV
DRAWN	ROOM	B	PEF-008	A
CHECKED				
ENGR	RPL	7/22/2015	SCALE: 1:22	SHEET 2 OF 2

THIRD ANGLE PROJECTION

PROPRIETARY AND CONFIDENTIAL
THE INFORMATION CONTAINED
HEREIN IS THE PROPERTY OF AVANT GARDE
REPRODUCTION OR TRANSMISSION
IN ANY FORM OR BY ANY MEANS
WITHOUT THE WRITTEN PERMISSION OF AVANT GARDE
IS PROHIBITED.

DO NOT SCALE DRAWING