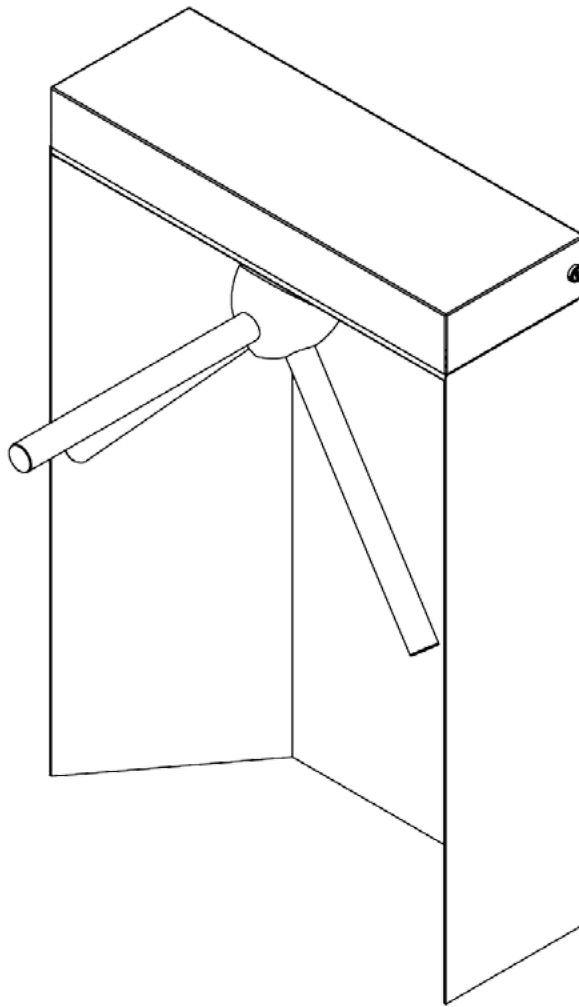




---

**EDC**  
**WAIST HIGH SECURITY TURNSTILE**  
(APPLICABLE TO ALL EDC MODELS)



**Installation and Maintenance Instructions**

---

Alvarado Manufacturing Company, Inc.

**Contents**

Contents ..... 2

Safety Icons ..... 2

Safety Precautions ..... 3

CE Compliance and Standards ..... 3

Installation Tools ..... 3

Parts List ..... 4

Common Terms ..... 4

Before You Begin ..... 5

Site Preparation ..... 5

    Slab Requirements ..... 5

    Space Requirements ..... 5

Installation Instructions ..... 6

    Anchoring the Turnstile ..... 6

Electrical Wiring Instructions ..... 7

    Primary Power Wiring ..... 7

    Access Control Wiring ..... 7

    10-7821 Turnstile Control Board Layout ..... 8

    10-7821 Terminal Descriptions ..... 9

Operations and Functionality ..... 11

    Passage Modes ..... 11

    Loss-of-Power Operation (Electric Models Only) ..... 11

    Drop-Arm (Optional) ..... 11

    User Notification Lights (Optional) ..... 11

    Local Battery Counter (Optional) ..... 12

    Key Override ..... 12

    Post-Installation Functions Check ..... 12

Cleaning and Maintenance ..... 13

    Maintenance Schedule ..... 13

    Exterior Maintenance ..... 14

    Interior Maintenance ..... 15

Troubleshooting ..... 18

Appendix A - Plan, Elevation and Footprint Drawings ..... 21

    EDC (27" Length) ..... 21

    EDC-E (Extended) ..... 22

    EDC-BN (Bullnose) ..... 23

    EDC-EBN (Extended Bullnose) ..... 24


Appendix B - Replacement Parts Kits ..... 25


Appendix C - 10-7822 Turnstile Control Board Layout and Terminal Descriptions ..... 29


Revision History ..... 32

**Safety Icons**

The following symbols are used throughout the manual to highlight important information and potential risks when installing, servicing or using the turnstiles covered in this manual.

 **WARNING** This symbol is used in this manual to warn installers and operators of potential harm. Please read these instructions very carefully.

 **CAUTION** This symbol is used in this manual to designate potential conditions that may pose a risk to pedestrians, personnel, property, and equipment Please read these instructions very carefully.

 **NOTE** This symbol is used in this manual to designate useful information for the installer and operator. Please read these instructions.



For questions, please contact Alvarado at +1 (909) 591-8431, Monday – Friday 7:00 am to 4:30 pm PST. Please read this manual completely before installing or operating the product.

**Safety Precautions**

**⚠ WARNING**

- Use only skilled individuals to install and service the turnstile.
- The turnstile is not a toy. Do not allow children to play on or near the turnstile.
- Follow a proper maintenance schedule using skilled individuals.
- Do not operate the turnstile if it has been damaged or is functioning incorrectly. Have the turnstile repaired by a skilled service person before placing back in use.
- Do not modify or alter the turnstile.
- Use only Alvarado parts when repairing or maintaining the turnstile.
- Ensure that all users are properly trained.
- Test the turnstile on a daily basis

**SAVE THESE INSTRUCTIONS**

After installation and adjustment, the installer is responsible for providing the owner or site manager with these instructions.

**CE Compliance and Standards**

This page defines the product labels required for compliance with LA Electrical Testing Laboratory and CE standards.

**CE Standards:**

a. Label (1) the Outlet Specification.

**~240V, 1800W**

b. Label (2) the Fuse Specification.

**F1.0A, 240V**

c. Label (3) the Warning, Risk of Electric Shock.

**⚠ DANGER**

d. Label (4) the Caution, Risk of Danger.

**⚠ DANGER**

**LA Electrical Testing Laboratory Standards:**

a. Label (1) the Outlet Specification.

**~120V, 1800 Watts Max.**

b. Label (2) the Fuse Caution.

**CAUTION:** For continued protection, against risk of fire or shock, replace with the same type and rating fuse.

c. Label (3) the Warning, Risk of Electric Shock.

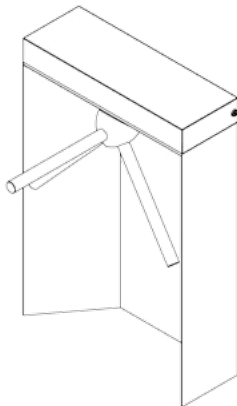
**WARNING:** For continued protection, against risk of fire or shock, replace with the same type and rating fuse.

**Installation Tools**

- Hammer Drill
- 1" Concrete Drill Bit
- Shop Vac
- 9/64" Allen Wrench
- #2 Phillips Head Screwdriver
- Torque Wrench (ft-lbs)
- 15/16" Socket
- Hammer
- Tape Measure
- Chalk
- Washer Shims
- 3mm Flat Head Screwdriver (Required for electric models only)

**Parts List**

This product is shipped with the required installation hardware. Make sure that no parts are missing and/or damaged before beginning installation. If parts are missing and/or damaged, please stop the installation and contact Alvarado. If additional copies of the installation instructions are required, please visit [www.alvaradomfg.com](http://www.alvaradomfg.com).



EDC Waist High Security Turnstile\*  
\*EDC (27" Length) model shown

**Also included:**

Hardware (per turnstile)

- Threaded Rods (Qty 2)
- Rod Cups (Qty 2)
- Concrete Anchors (Qty 2)

Keys (per turnstile)

- Turnstile Lid Keys (Qty 2)
- Key Override Keys (Qty 2)

**NOTE**

Keys are taped to the turnstile arms. Be sure to locate the keys before discarding any shipping materials.

**Common Terms**

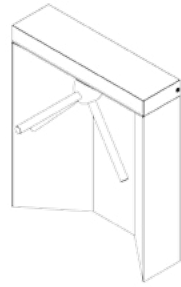
<b>Activation</b>	Activation (unlocking) of electric models is accomplished by providing a momentary dry contact signal of .5 to 1 second to the appropriate location on the turnstile control board. Activations are not buffered. After an activation is received, the turnstile will not accept another activation until the turnstile is rotated or the automatic turnstile relock period has expired.
<b>Clockwise Rotation (CW)</b>	Turnstile arms rotate in a clockwise direction when viewed looking down from the non-arm side of the cabinet.
<b>Counterclockwise Rotation (CCW)</b>	Turnstile arms rotate in a counterclockwise direction when viewed looking down from the non-arm side of the cabinet.
<b>Fail-Lock</b>	Upon loss of power, the turnstile arms cannot be rotated in either direction.
<b>Fail-Safe</b>	Upon loss of power, the turnstile arms rotate freely in both directions.
<b>Key Override</b>	All EDC turnstiles come with key overrides located on the underside of the front panel. Key overrides are used to toggle between free passage and controlled passage modes (electric models only). There is one key override provided for each rotation direction.
<b>Automatic Turnstile Relock</b>	When the turnstile receives an activation (unlock signal), the user is allowed a set time to pass through the turnstile before it automatically relocks. The factory default setting is 20 seconds. The turnstile control board allows the user to change this setting to 5, 10, 15 or 20 seconds.
<b>Controlled Passage Mode</b>	The arms are locked in the home position. Upon receipt of an activation from an access control system, the turnstile unlocks in the appropriate direction allowing a single passage. The arms relock after the user has passed through the turnstile or when the automatic turnstile relock period has expired. Controlled Passage mode can be either single direction or bidirectional.
<b>Free Passage Mode</b>	An authorization signal is not required for a user to pass through the turnstile. Either rotation direction can be set to Free Passage mode using the key overrides located on the underside of the cabinet.
<b>No Passage Mode</b>	The turnstile arms are locked and remain locked even if valid credentials are presented to the access control system.

**Before You Begin**

The EDC product line of waist high security turnstiles include manual and electric models with varying cabinet sizes and styles. This manual focuses on the EDC (27" length) model for the basis of instruction; however, most steps are identical across models. Any differences will be called out as applicable. Instructions apply to the following models:



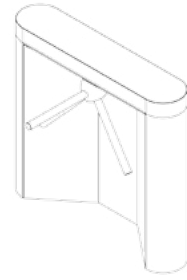
EDC (27" Length)



EDC-E (Extended)



EDC-BN (Bullnose)



EDC-EBN (Extended Bullnose)

**Site Preparation**

Use only skilled technicians for site preparation and installation of the turnstile using Alvarado's instructions. Refer to the footprint and plan drawings [Figures 1A & 1B] to determine the installation location and conduit requirements. **See Appendix A for other models.**

**Slab Requirements**

The following must be taken into consideration when selecting the installation location:

- Use a level solid concrete pad with a minimum thickness of 4" (101.5mm). Ensure concrete pad extends a minimum of 5" (127mm) from all sides of the turnstile footprint.
- Do not install the turnstile on asphalt.
- Stub up conduit in accordance with local electrical codes.

**Space Requirements**

The following must be taken into consideration when determining space requirements:

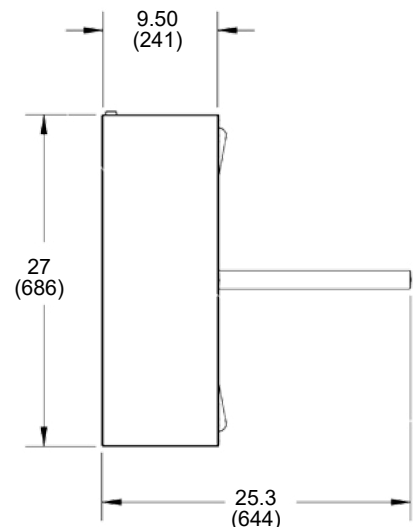
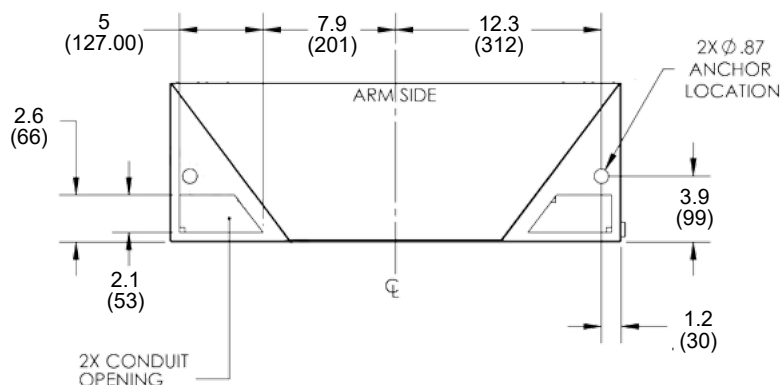
- Always verify the layout of the turnstile(s) before installation.
- There must 2" (50.8mm) of clearance between the turnstile arm and the adjacent turnstile or barrier.

**NOTE**

See Appendix A for footprint and dimension drawings for other models.

**Fig. 1B** EDC (27" Length) Plan View

**Fig. 1A** EDC (27" Length) Footprint

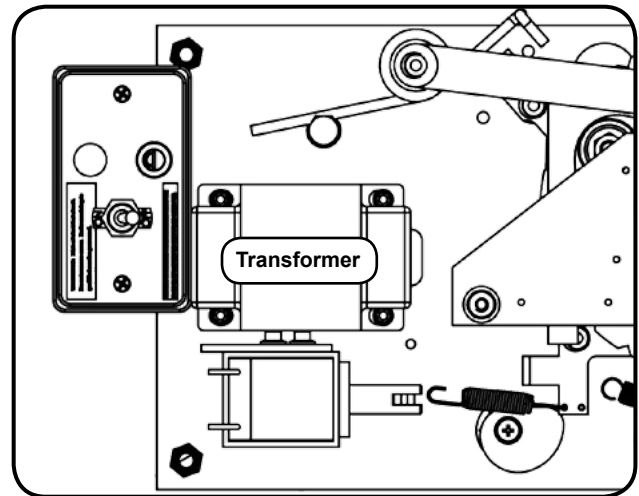


**Installation Instructions**

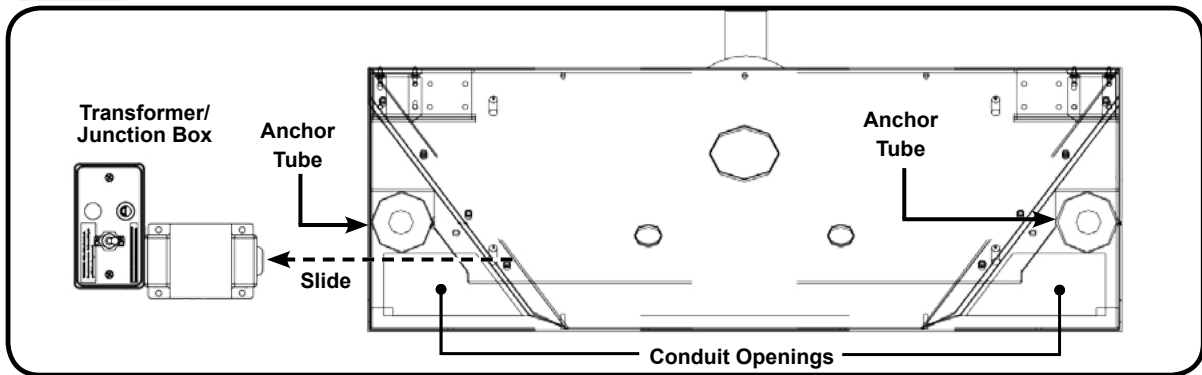
**Anchoring the Turnstile**

1. Place the turnstile in the desired location.
2. Using a lid key, unlock and open the turnstile lid. There is a lid lock on each side of the turnstile.
3. Using a 9/64" Allen wrench, remove the four (4) transformer screws [Figure 2].
4. Slide the transformer/junction box to the side to gain access to the welded post anchor tube beneath [Figure 3].
5. Route primary power wiring from the appropriate conduit opening into the turnstile [Figure 3].

**Fig. 2 Transformer Screws**

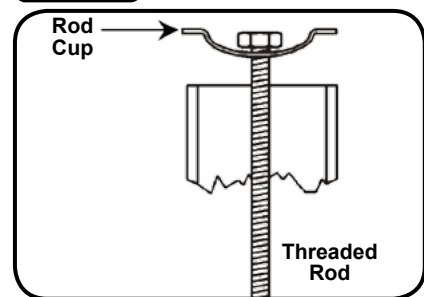


**Fig. 3 Accessing the post anchor tubes**



6. To mark the anchor holes, you will need to insert a chalked threaded rod down the post anchor tubes. To help center the threaded rod in the post anchor tube, use a rod cup as shown in [Figure 4].
7. Chalk the bottom of the shaft rod. Run the chalked threaded rod down a post anchor tube and gently tap the rod on the concrete to mark the anchor's center location. Repeat for other post anchor tube.
8. Move the turnstile to the side.
9. Using a hammer drill fitted with a 1" concrete bit, drill each anchor hole to a depth of 3" (76.2mm).

**Fig. 4 Rod Cup & Threaded Rod**

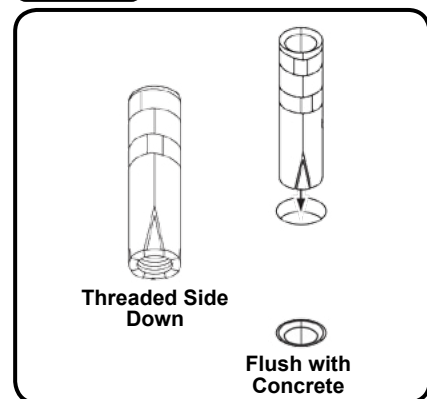


**NOTE**

Vacuum debris from the anchor holes before installing the anchors. If the holes are not clear of debris, the anchors may not tighten correctly.

10. Insert anchors into the drilled holes with the threaded ends down. If needed, use a hammer to tap the anchor into place. Ensure that the anchors are flush with the concrete floor [Figure 5].
11. Return the turnstile to the install location, ensuring the anchors are centered in the post anchor tubes.

**Fig. 5 Inserting Anchors**



**Anchoring the Turnstile (cont.)**

12. Insert a threaded rod & cup assembly down a post anchor tube and into the anchor. Repeat with the other threaded rod & cup assembly and post anchor tube.
13. Check that the turnstile is level and does not rock. If the turnstile rocks, shim as necessary using washer shims.
14. Using a torque wrench (ft.-lbs.) and 15/16" socket, torque the threaded rods to 80 ft.-lbs.
15. Return the transformer/junction box to its mounting location. Using a 9/64" Allen wrench, tighten the four (4) transformer/junction box screws.

**For manual (non-electric) turnstiles, this concludes the installation.**

**Electrical Wiring Instructions**

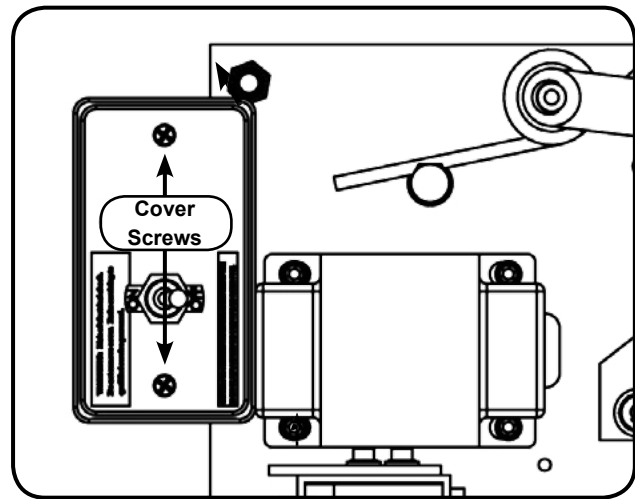
**Primary Power Wiring**

**⚠ WARNING**

Use a licensed electrician for the following steps, and adhere to all applicable local codes.

16. Make sure primary power is turned OFF.
17. Make sure the junction box switch is set to OFF.
18. Using a #2 Phillips head screwdriver, remove the two (2) junction box cover screws and set the cover aside [Figure 6].
19. Locate the power wires inside the junction box.
20. Run the primary power wires through the appropriate knock-out on the junction box [Figure 6].
21. Connect the power wires according to your power configuration [Table 1A & 1B].
22. Secure the wires and wire nuts.
23. Verify that all contacts are secured and isolated from any possible shorts.
24. Tuck excess wire into the junction box.
25. Using a #2 Phillips screwdriver, re-attach the junction box cover.

**Fig. 6** Junction Box (110V Version Shown)



**Table 1A** 110 VAC Connections

Junction Box	Primary Power
Green Screw	Green Wire
Gold Screw	Black Wire
Silver Screw	White Wire

**Table 1B** 220 VAC Connections

Junction Box	Primary Power
Green/Yellow Screw	Green/Yellow Wire
Gold Screw	Blue Wire
Gold Screw	Brown Wire

**NOTE**

For a DC primary power connection, run 13.5VDC to the J4 connector on the turnstile control board.

**Access Control Wiring**

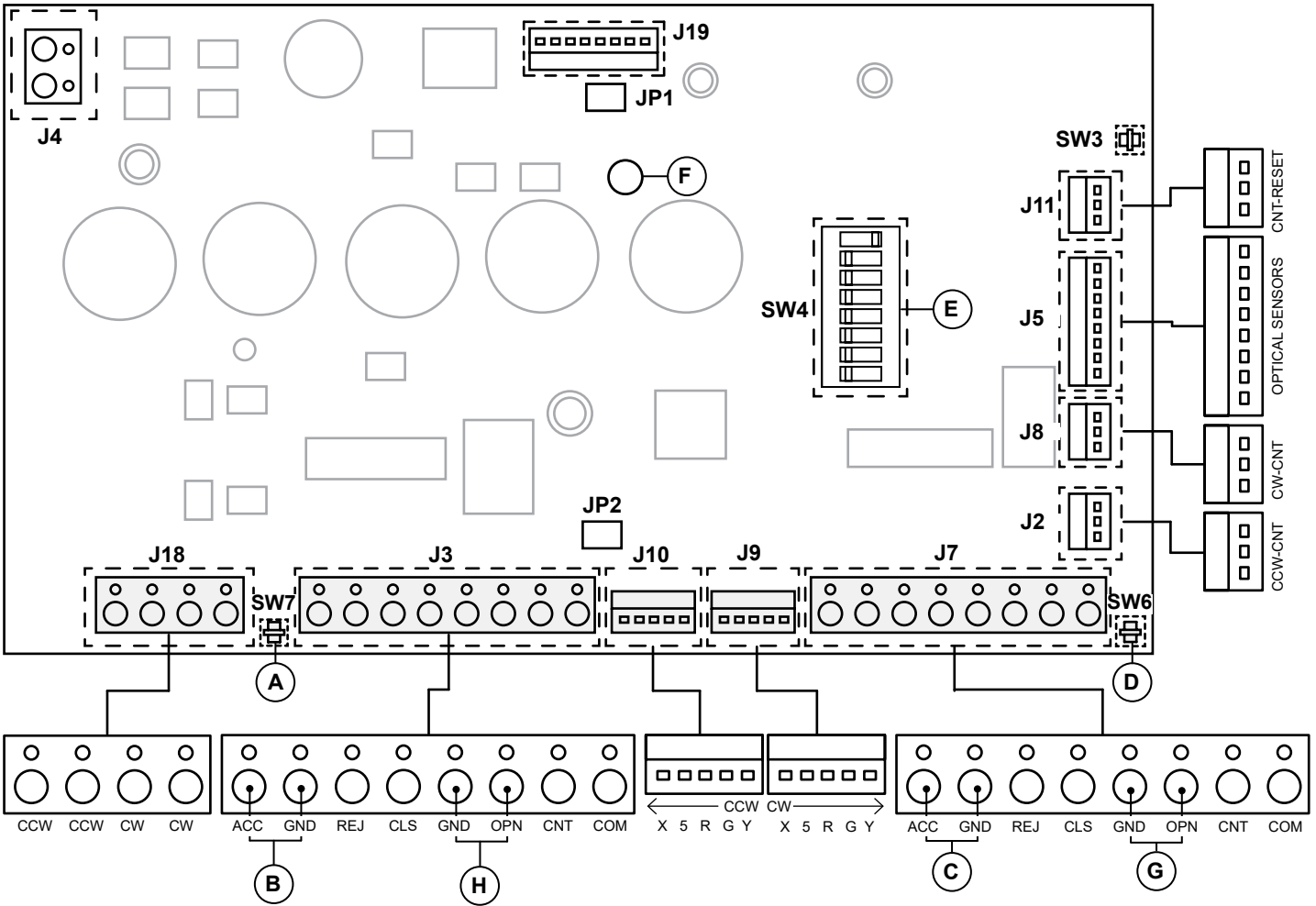
26. Using a 3mm flat head screwdriver, connect access control wiring to the turnstile control board's J3 and/or J7 terminal connectors [Figure 7]. Refer to the 10-7821 Turnstile Control Board Layout and Terminal Descriptions sections on the following pages for more information.

**For electric turnstiles, this completes the installation. Proceed to the Operations and Functionality section on page 11, and the Post-Installation Functions Check section on page 12.**

10-7821 Turnstile Control Board Layout

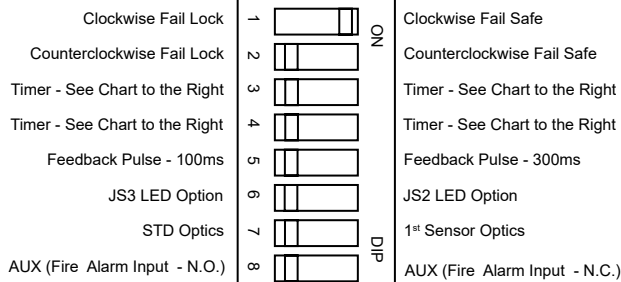
**NOTE** Refer to Appendix C for 10-7822 turnstile control board used in conjunction with the drop-arm option.

**Fig. 7** 10-7821 Turnstile Control Board



LEGEND	
Item	Name
A	CCW Test Activation Switch (SW7)
B	Access Control Activation - CCW
C	Access Control Activation - CW
D	CW Activation Test Switch (SW6)
E	DIP Switches (SW4)
F	Green LED
G	Fire Alarm System Connection - CW
H	Fire Alarm System Connection - CCW

**Fig. 7A** SW4 Layout



**NOTE** Default DIP switch settings pictured above are for Fail-lock/Fail-safe configurations.

**Fig. 7B** Automatic Turnstile Relock Setting Switches

Automatic turnstile relock Setting (Positions T3 and T4)	T3	T4
5 seconds	ON	ON
10 seconds	ON	OFF
15 seconds	OFF	ON
20 seconds (Default)	OFF	OFF



**10-7821 Terminal Descriptions**

**NOTE**

Refer to the 10-7821 Turnstile Control Board Layout as needed.

BOARD	NAME	DESCRIPTION	EXPLANATION
J18	CCW	Solenoid VDC wire connection - CCW Direction	Connection for counterclockwise solenoid. Universal polarity.
J18	CCW	Solenoid VDC wire connection - CCW Direction	Connection for counterclockwise Solenoid. Universal polarity.
J18	CW	Solenoid VDC wire connection - CW Direction	Connection for clockwise solenoid. Universal polarity.
J18	CW	Solenoid VDC wire connection - CW Direction	Connection for clockwise solenoid. Universal polarity.
SW7	CCW Entry Activation Test Button	Allows user to test turnstile activation - CCW Direction	Depressing button simulates input to J3 ACC, "Entry Accept". If turnstile solenoid "fires" after depressing button AND re-locks after a single rotation of the arms or upon time out, the turnstile is functioning correctly in the counterclockwise direction.
J3	ACC Entry Accept	"Card Authorized" input connection from the access control system - CCW Direction	This connection is used to tell the turnstile to unlock. The turnstile control board will accept a normally-open dry-contact signal of .5 seconds to 1 second from the access control system and allow one rotation of the arms before re-locking.
J3	GND Ground	Ground wire connection from the access control system - CCW Direction	Ground wire connection position for ACC and REJ contact signal.
J3	REJ Entry Reject	"Card Reject" input connection from the access control system - CCW Direction	This connection is used to tell the turnstile to remain locked. The access control system has determined that the card presented is unauthorized for entry.
J3	CLS Close Passage	Connection for placing turnstile in locked "CLOSED" status - CCW Direction	Providing a continuous dry-contact signal at this terminal places the turnstile in a locked "CLOSED" mode. This mode overrides the access control system operation. If status lights are installed (Location J19) the red light will be illuminated continuously.
J3	GND Ground	Ground wire connection for "OPN/CLS" lane control - CCW Direction	Ground wire connection for "OPN/CLS" passage control.
J3	OPN Open Passage	Connection for placing turnstile in "OPEN" status - CCW Direction	Providing a continuous dry-contact signal at this terminal places the turnstile in an "OPEN" mode. Typically, this terminal is used to connect the fire alarm system (normally open type) when the turnstile is configured for counterclockwise rotation in the exit direction.
J3	CNT Passage Count	Confirmation signal upon turnstile rotation - CCW Direction	Outputs a dry contact upon rotation of the turnstile. This feature can be used to output a "count" signal to an external system such as Alvarado's GateWatch or to provide feedback to the access control system that a turnstile rotation has taken place.
J3	COM Passage Count	Confirmation signal upon turnstile rotation - CCW Direction	Common dry contact connection for CNT count signal output. See J3 CNT description.
J10	X5RGY-CCW	Connection for Activation Lights - CCW Direction	Connection for JS2 and JS3 activation lights.
J9	X5RGY-CW	Connection for Activation Lights - CW Direction	Connection for JS2 and JS3 activation lights.
J7	ACC Entry Accept	"Card Authorized" input connection from the access control system - CW Direction	This connection is used to tell the turnstile to unlock. The turnstile control board will accept a normally-open dry-contact signal of .5 seconds to 1 second from the access control system and allow one rotation of the arms before re-locking.
J7	GND Ground	Ground wire connection from the access control system - CW Direction	Ground wire connection position for ACC and REJ contact signal.
J7	REJ Entry Reject	"Card Reject" input connection from the access control system - CW Direction	This connection is used to tell the turnstile to remain locked. The access control system has determined that the card presented is unauthorized for entry.
J7	GND Ground	Ground wire connection for "OPN/CLS" lane control - CW Direction	Ground wire connection for "OPN/CLS" passage control.
J7	CLS Close Passage	Connection for placing turnstile in "OPEN" status - CW Direction	Providing a continuous dry contact at this terminal places the turnstile in a locked "CLOSED" mode. This mode overrides the access control system operation. If status lights are installed (Location J19) the red light will be illuminated continuously.

**10-7821 Terminal Descriptions (cont.)**

BOARD	NAME	DESCRIPTION	EXPLANATION
J7	OPN Open Passage	Connection for placing turnstile in "OPEN" status - CW Direction	Providing a continuous dry-contact signal at this terminal places the turnstile in an "OPEN" mode. Typically, this terminal is used to connect the fire alarm system (normally open type) when the turnstile is configured for clockwise rotation in the exit direction (default).
J7	CNT Passage Count	Confirmation signal upon turnstile rotation - CW Direction	Outputs a dry-contact signal upon rotation of the turnstile. This feature can be used to output a "count" signal to an external system such as Alvarado's GateWatch or to provide feedback to the access control system that a turnstile rotation has taken place.
J7	COM Passage Count	Confirmation signal upon turnstile rotation - CW Direction	Common dry-contact signal for CNT count signal output. See J3 CNT description.
SW6	CW Entry Activation Test Button	Allows user to test turnstile activation - CW Direction	Depressing button simulates input to J7 ACC, "Entry Accept". If turnstile solenoid "fires" after depressing button AND re-locks after a single rotation of the arms or upon time out, the turnstile is functioning correctly in the clockwise direction.
J2	CCW-CNT	Output of contact closure upon turnstile rotation - CCW Direction	Single throw, relay output for connection to Alvarado battery-powered, digital counter.
J8	CW-CNT	Output of contact closure upon turnstile rotation - CW Direction	Single throw, relay output for connection to Alvarado battery-powered, digital counter.
J5	Optical Sensors	Connection for sensors	The turnstile control board uses input from the sensors to monitor rotation of the arms.
J11	CNT- RESET	Connection for counter-reset key switch	Normally-open dry-contact connection if counter wires are attached to J2 and/or J8 connections. A 2-position electrical key switch is connected here to provide a reset to the individual counters.
SW3	Reset counters	Local-Battery Counter-Reset Switch	If counter wires are attached to the board (J2 and J8), depressing this button will reset the counters. If two counters are installed and wired, both counters will be reset.
J19		Connection for EL function light board	If red/green status lights are used, the green light signifies that the turnstile is ready to accept an activation for the direction shown. When the CLS and GND connection is closed, the red light will be illuminated and signifies that the turnstile will not accept an activation. Refer to description for CLS on J3 and J7.
J4	Power Input	Connection for low voltage power	The turnstile control board will accept 10 VAC or 13.5 VDC power. If primary power is not run to the turnstile, low-voltage power is connected here and the green ground wire must be grounded to the chassis.

**SW4 Layout**

LEFT / OFF	Switch Position	Switch Position	RIGHT / ON
Sets solenoid control for the clockwise direction in fail lock configuration. Power is applied to solenoid upon activation signal to release lock arm for rotation.	<b>CWFL</b>	<b>FS</b>	Sets solenoid control for the clockwise direction in fail safe configuration. Power is applied to solenoid for locked condition and removed upon activation signal to release lock arm for rotation.
Sets solenoid control for the counterclockwise direction in fail lock configuration. Power is applied to solenoid upon activation signal to release lock arm for rotation.	<b>CCWFL</b>	<b>FS</b>	Sets solenoid control for the counterclockwise direction in fail-safe configuration. Power is applied to solenoid for locked condition and removed upon activation signal to release lock arm for rotation.
Adjusts automatic turnstile relock. See Figure 7 for settings.	<b>T3</b>	<b>T3ON</b>	Adjusts automatic turnstile relock. See [Figure 7] for settings.
Adjusts automatic turnstile relock. See Figure 7 for settings.	<b>T4</b>	<b>T4ON</b>	Adjusts automatic turnstile relock. See [Figure 7] for settings.
Sets Length of time of contact closure on CNT and COM feedback to 100ms.	<b>100</b>	<b>FBPL</b>	Sets Length of time of contact closure on CNT and COM feedback to 300ms.
Set switch to left when using Red/Yellow/Green activation lights.	<b>JS3</b>	<b>JS2</b>	Set switch to right when using Red/Green activation lights.
Sets operation to standard optical sensor configuration for passage feedback after second sensor detection.	<b>STD</b>	<b>ROFP</b>	Sets operation to custom optical sensor configuration for passage feedback on first sensor detection.
Configures OPN terminals as normally open (N.O.). OPN inputs are used for fire alarm / free passage modes.	<b>AUX</b>	<b>AUX</b>	Configures OPN terminals as normally closed (N.C.). OPN inputs are used for fire alarm / free passage modes.

## Operations and Functionality

### Passage Modes

Electric turnstiles may be configured for any combination of the following passage modes:

**Controlled Passage** - The arms are locked in the home position. Upon receipt of an authorization signal from an access control system, the turnstile unlocks in the appropriate direction allowing a single passage. The arms re-lock after the user has passed through the turnstile, or when the automatic turnstile relock period has been reached. Controlled passage can be either single direction or bidirectional.

**Free Passage** - An authorization signal is not required for a user to pass through the turnstile. Either rotation direction can be set to free passage using the key overrides located on the underside of the cabinet.

**No Passage** - The turnstile arms are locked and remain locked even if valid credentials are presented to the access control system.

Manual (Non-Electric) turnstiles may be configured for any combination of the following passage modes:

**Free Passage** - The turnstile arms are unlocked and rotate freely.

**No Passage** - The turnstile arms are locked.

### Loss-of-Power Operation (Electric Models Only)

The turnstile can be configured to operate in one of two ways during a loss-of-power event:

**Fail-Lock** - The turnstile arms remain locked in both directions. In the power off condition, passage may be allowed using the key overrides.

**Fail-Safe** - The turnstile arms rotate freely in both directions.

### Drop-Arm (Optional)

The horizontal turnstile arm drops down to provide a clear passageway upon loss of power or receipt of a fire alarm input located on the turnstile control board.

When the fire alarm signal is removed, the drop arm must be moved back to the horizontal position manually.

#### NOTES

The drop arm option includes the 10-7822 turnstile control board. Refer to Appendix C on Page 29 for 10-7822 layout and terminal descriptions.

Drop arm option is available on fail-lock solenoid configuration only.

### User Notification Lights (Optional)

Electric turnstiles can be equipped with user notification lights (JS2) that indicate turnstile status. The user notification lights are installed to the turnstile lid and can be configured to function in the following manners:

- **Red** – Indicates the turnstile is locked and ready for card presentation.
- **Green** – Indicates the access system has provided the turnstile control board with an activation indicating an “authorized” card has been presented. When the green light illuminates, the turnstile is unlocked and ready for passage.
- **Red** – Indicates the access system has provided the turnstile control board with an activation indicating an “unauthorized” card has been presented. When the red light illuminates, the turnstile will remain locked.
- **Green** – Indicates the access system has provided the turnstile control board with an activation indicating an “authorized” card has been presented. When the green light illuminates, the turnstile is unlocked and ready for passage.
- **Yellow** – Indicates the turnstile is locked and ready for card presentation.

### Local Battery Counter (Optional)

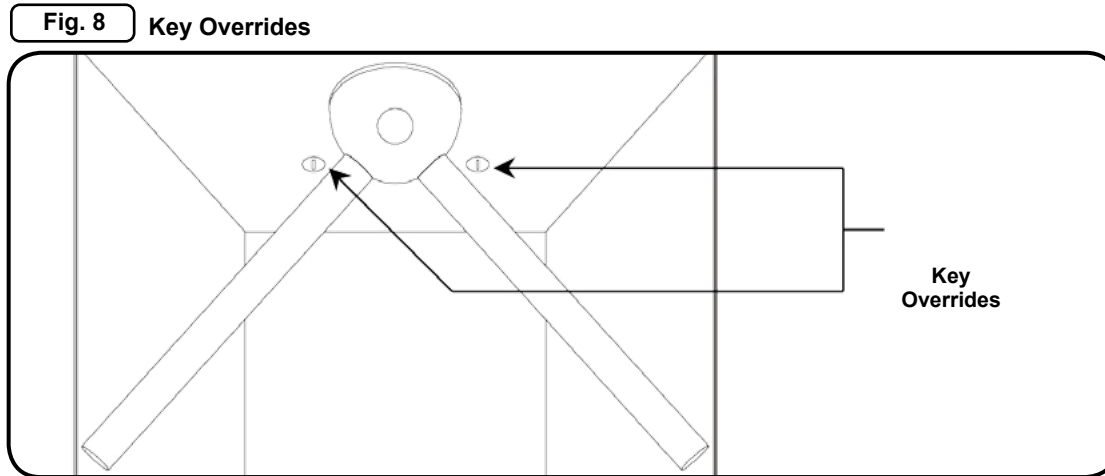
A lithium battery-powered LCD counter can be installed on electric and non-electric models. Each rotation of the turnstile arm generates a count. One counter is required per direction. Counters can be ordered as reset or non-reset versions.

1. To reset the counter, use the counter reset key and turn 90°. The counter reset lock is located next to the counter display.

### Key Override

The key override manually locks or unlocks the turnstile in the desired direction. The key overrides are located on the underside of the front panel near the turnstile arms base [Figure 8].

1. To engage the key override, turn the key 90°.



**Fig. 8** Key Overrides

**NOTE**

When not in use, store the keys in a safe location.

### Post-Installation Functions Check

1. Ensure the junction box switch is set to ON.
2. Confirm the turnstile arms are locked in the controlled direction(s).
3. Provide an activation. Confirm the turnstile unlocks and rotates.
4. Provide an activation again, but allow the automatic turnstile relock period to be reached (default is 20 seconds). Confirm that the turnstile re-locks.

**NOTE**

The automatic turnstile relock setting can be configured using DIP switch bank SW4 on the turnstile control board [Figure 7].

5. Set the junction box switch to OFF.
6. Confirm the following:
  - If the turnstile is configured for Fail-Lock operation, confirm that the turnstile remains locked in the controlled direction(s) upon loss of power.
  - If the turnstile is configured for Fail-Safe operation, confirm that the turnstile rotates freely upon loss of power.
  - If the drop arm option is installed, verify the horizontal arm drops to the open position. Manually move the drop arm back to the closed position.
7. Set the junction box switch to ON.
8. Close and lock the turnstile lid.

**Cleaning and Maintenance**

**Maintenance Schedule**

In order to maximize the longevity of the turnstile, Alvarado recommends adhering to the following maintenance schedule. The maintenance schedule is based on what we would consider a typical installation, which is in a temperate climate with usage averaging 7500 activations per week. All maintenance items are described in more detail beginning on Page 14.

ITEM #	SERVICE	DAILY	6 MONTHS	YEARLY
<b>EXTERIOR MAINTENANCE</b>				
1	Wipe down turnstile exterior with clean, damp cloth.	X		
2	Apply polish to all exterior surfaces.		X	
3	Apply sealant / wax to stainless steel / powder-coated surfaces.			X
4	Chemically passivate stainless steel surfaces.	Perform as needed		
<b>INTERIOR MAINTENANCE</b>				
5	Verify the threaded rods used to anchor the turnstile are torqued to 80 ft-lbs.		X	
6	Clean internal components with compressed air.		X	
7	Inspect all wires and contacts for exposure to metal parts that may lead to a short.		X	
8	Clean, test, and validate turnstile locking mechanism.		X	
9	Verify hydraulic closure unit is functioning properly.		X	
10	Lubricate turnstile pivot points, roller bearings, and solenoid plungers with DuPont Teflon Non-Stick Dry-Film Lubricant.		X	
11	Apply DeoxIT to all turnstile control board terminals and wire harnesses.			X

**IMPORTANT**

If the turnstile is installed in a harsh outdoor environment such as a coastal area, very hot or cold area, or area with high levels of dust and contaminants, or usage exceeds 7500 activations per week, we recommend performing the 6 month and yearly maintenance items every 3 months and 6 months, respectively.

**Cleaning and Maintenance (cont.)****Exterior Maintenance****NOTE**

Refer to Page 13 for the Maintenance Schedule.

**1) Wipe down turnstile with a clean, damp cloth.**

Regular cleaning is the best way to maintain the turnstile's exterior finish. This is especially true for stainless steel surfaces, where the goal should be to keep the protective chromium-oxide layer intact.

Regular cleaning can be accomplished by wiping all surfaces down with a clean and damp rag. For turnstiles that are installed in harsh outdoor environments such as refineries or chemical plants, rinsing the stainless steel surface with fresh water to wash away accumulated chemicals, materials, and particulates is recommended prior to wiping down. Always try to clean equipment immediately after contact with chlorides (chlorine powder, salt melt, seawater, etc.).

**2) Apply polish to all exterior surfaces.**

Polish should be applied on a regular basis to preserve the aesthetic appeal and protect against rust, stubborn stains, and heavy spotting. Our #1 recommendation for polish is **Prism Liquid - Metal Polish**. This product is safe for use on stainless steel, aluminum, power-coated, and acrylic surfaces.

To apply, follow the manufacturer's instructions, but in brief: a) apply polish with a soft cloth, b) rub in a back-and-forth motion in the direction of the grain, c) buff with a clean towel until all residue is gone and the finish is bright and shiny. If rust, stubborn stains, or heavy spotting are present, apply and rub polish using Scotch-Brite Hand Pads (7445) or (7447) grits. Never use steel wool. Again, make sure to polish in the direction of the grain. Prism Liquid - Metal Polish can be purchased at [www.prismpolish.com](http://www.prismpolish.com).

Any deep scratches or chips in powder-coated finishes should be touched up to prevent a rust spot from forming. If left untreated, rust will spread.

**3) Apply sealant to stainless steel / powder-coated surfaces.**

As a best practice, we recommend all stainless steel and powder-coated surfaces receive an application of sealant for maximum protection throughout the year between polishes (especially when the turnstiles are subject to extreme weather and excessive air- and water-borne contaminants). Sealant will provide long-lasting protection from UV rays, acid rain, air- and water-borne contaminants, and oils. The sealant we recommend is **Prism Mirage Sealant and Protectant**. This particular sealant is wax-free, therefore it will not yellow, get sticky in the heat, or attract dirt. Sealant should be applied directly after polishing.

To apply, follow the manufacturer's instructions, but in brief: a) apply sealant with a damp (not wet) sponge, one section at a time, using a circular motion, b) allow to haze, c) buff with a clean and dry cloth or electric buffer. Prism Mirage Sealant and Protectant can be purchased at [www.prismpolish.com](http://www.prismpolish.com).

**4) Chemically passivate stainless steel surfaces.**

If excessive rust and pitting has been allowed to develop, and polishing has not been effective in removal, chemical passivation is the next step. Chemical passivation is a process that is used to make the surface of stainless steel "passive." Passive means that the surface is resistant to corrosive reactions (such as rust).

To chemically passivate stainless steel, Alvarado recommends the use of a citric acid product called **CitriSurf2310**, available from Stellar Solutions at [www.citrisurf.com](http://www.citrisurf.com). This product is especially formulated to clean and passivate stainless steel and can be used in the field. Follow the manufacturer's directions.

In especially harsh environments, it is possible that chemical passivation will be need to performed on a more frequent basis.

**Cleaning and Maintenance (cont.)****Interior Maintenance****5) Verify threaded rods are torqued to 80 ft-lbs.**

Using a torque wrench (ft-lbs.) and 15/16" socket, verify the threaded rods are torqued to 80 ft-lbs.

**NOTE**

This procedure requires the junction box / transformer be removed in order to access the left-hand threaded rod. Refer to Pages 6 -7 for removal instructions.

**6) Clean internal components with compressed air.**

Using compressed air, blow dust, dirt, and debris from the interior of the turnstile. Pay extra-special attention to the turnstile control board, optical sensor, and solenoids. Keep the can upright as much as possible to avoid liquid discharge from the nozzle.

**7) Inspect all wires and contacts for exposure to metal parts that may lead to a short.**

Inspect all junction box wiring, turnstile control board and solenoid power wires, and optical sensor wire harness.

**CAUTION**

MAKE SURE POWER IS TURNED OFF AT THE BREAKER BEFORE INSPECTION

**8) Clean, test, and validate turnstile locking mechanism**

- a. Check solenoid and return springs for any extensive wear or deformation.  
**NOTE:** Replace springs every 5 years.
- b. Check solenoids for proper engagement in the locked and unlocked positions.  
**NOTE:** Fail-Safe operation requires that the solenoid be engaged for at least 30 minutes prior to testing.
- c. Verify optical encoder wheel passes through the center off the optical sensors.
- d. Perform 10 rotations in each direction and validate locking / unlocking functionality. The turnstile should re-lock after the turnstile arms are rotated.

**9) Verify the hydraulic closure unit is functioning properly.**

Verify the hydraulic closure is properly adjusted by observing the rotation of the turnstile arms. If the turnstile is electrically controlled, use the key override to enable free passage prior to performing steps A - C.

- a. Spin the arm once in the testing direction. The turnstile arm should rotate once and stop in the home position.
- b. If the turnstile over-rotates, increase the hydraulic tension by removing the cotter-type pin at the top of the hydraulic closure. Tighten the adjusting screw (clockwise) with a slotted screwdriver. Put the pin back in and re-test. Test in increments of 1/8 of a turn, not exceeding 1 full turn (360°). **NOTE:** DO NOT bottom out the adjusting screw.
- c. If the turnstile under-rotates (returns to standard position very slowly), decrease the hydraulic tension by removing the cotter-type pin at the top of the hydraulic closure. Loosen the adjusting screw (counterclockwise) with a slotted screwdriver. Put the pin back in and re-test. Test in increments of 1/8 of a turn, not exceeding 1 full turn (360°).



**Interior Maintenance (cont.)**

**10) Lubricate turnstile pivot points, roller bearings, and solenoid plungers.**

Alvarado strongly recommends **DuPont Teflon Non-Stick Dry-Film Lubricant (Liquid Form)** be used when lubricating the turnstile. This lubricant does not leave an oily film and creates a dirt-resistant coating.

DuPont Teflon Non-Stick Dry-Film Lubricant (Liquid Form) can be purchased online at [www.amazon.com](http://www.amazon.com).

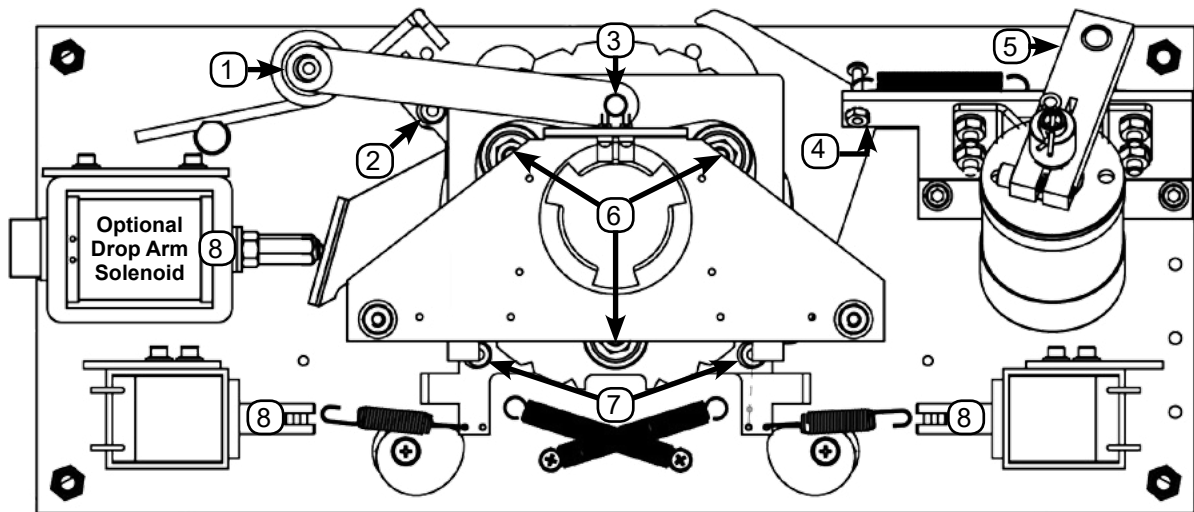
**Pivot Points and Roller Bearings**

- a. Wipe down all component to be lubricated with a clean rag.
- b. Apply Teflon Non-Stick Dry-Film Lubricant to the locations indicated in [Figure 9].

**Solenoid Plungers**

- a. Remove the solenoid spring shank from the plunger. Remove plunger and set aside.
- b. Using a cotton swab dipped in isopropyl alcohol, clean the solenoid cavity and plunger, and allow to dry.
- c. Coat the first 1 - 1.5" of the plunger with a thin layer of Teflon Non-Stick Dry-Film Lubricant. Allow to dry.
- d. Insert plunger into the solenoid cavity and reinstall solenoid spring.
- e. Repeat steps a - d on second solenoid and drop-arm solenoid (if installed).

**Fig. 9** Lubrication Points



- |                              |  |
|------------------------------|--|
| 1. Compression Arm Pivot     | 6. Roller Bearings                     |
| 2. Reversing Pawl Pivot      | 7. Lock Arm Pivots                     |
| 3. Compression Shoe Pivot    | 8. Solenoid Plungers                   |
| 4. Cam Shock Absorber Pivots | 9. Optional Drop Arm Pivot (not shown) |
| 5. Hydraulic Closure Pivot   |  |



Interior Maintenance (cont.)

11) Apply DeoxIT to all turnstile control board terminals and wire harnesses.

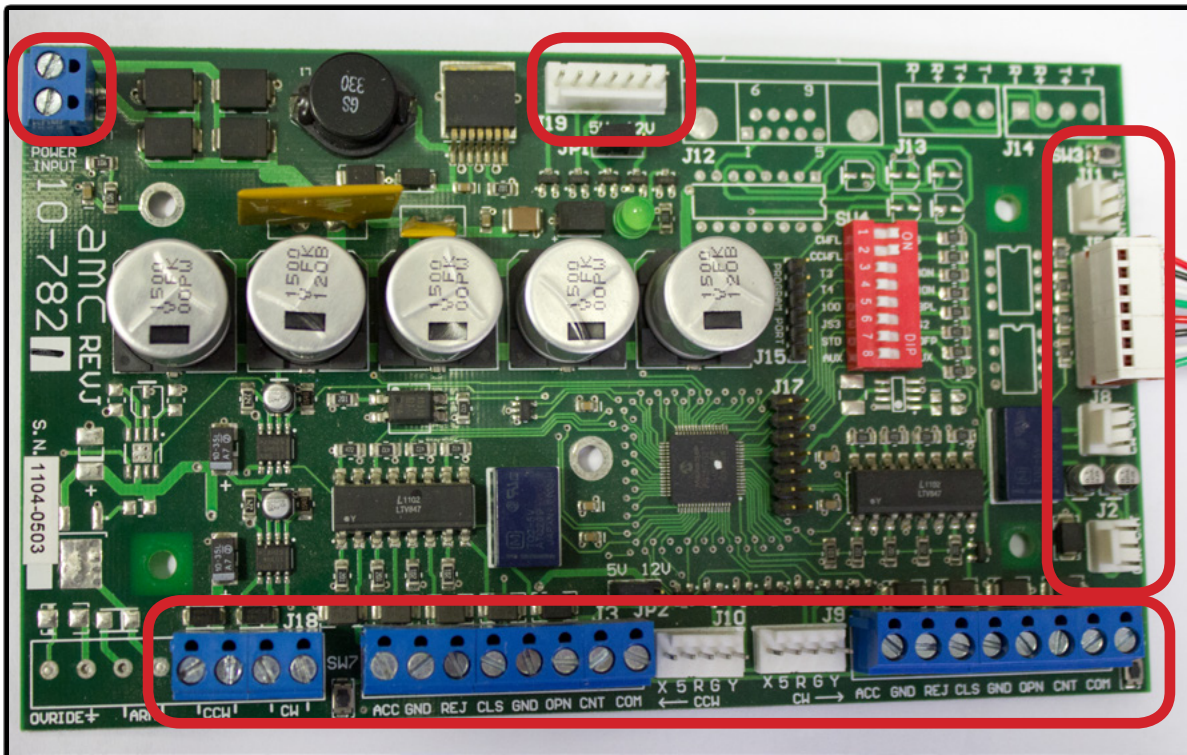
DeoxIT is a contact cleaner / lubricant that is quite beneficial for power and data connections. Yearly applications of this product is strongly recommended in locations with harsh weather or high levels of air-borne contaminants.

We recommend **DeoxIT D100L Needle Dispenser (P/N D100L-25C)** for its balance of cleaning and lubrication qualities, as well as ease of application. DeoxIT can be purchased at [www.caig.com](http://www.caig.com).

**CAUTION** ENSURE PRIMARY POWER IS TURNED OFF PRIOR TO PERFORMING THIS PROCEDURE.

- a. Disconnect all wires and wire harnesses from the turnstile control board [Figure 10].
- b. Inspect wires and contacts for damage.
- c. Apply DeoxIT to contacts. Allow to dry (2- 5 minutes).
- d. Reconnect wires and wire harnesses to the turnstile control board.
- e. Power on turnstile and check functionality.

Fig. 10 Turnstile Control Board (10-7821)



**Troubleshooting**

ITEMS TO CHECK FIRST:

- Always check for and remove any debris in or around the solenoid plunger (do not, however, lubricate the solenoid plunger. It is designed to operate “dry”.)
- Always check the wiring of the turnstile for any loose or bad connections.
- REMINDER NOTE: You can always test the functionality of the turnstile by pressing the activation test switch(s) on the turnstile control board [Figure 7].

Symptom	Possible Cause	Solution
<b>Turnstile does not unlock</b>	There is no power to the turnstile (Fail-Lock units only).	<p>Confirm that the ON/OFF switch is in the ON position.</p> <p>Confirm that the fuse is still good. If necessary replace the fuse.</p> <p>Confirm that the LED on the turnstile control board is on and not flickering. If the LED on the turnstile control board is not lit, verify that proper voltage (110 -120VAC) is being provided to the junction box inside the turnstile. Do this by plugging in any device such as a light, drill, radio, etc.</p> <p>If the proper voltage (110-120VAC) is being provided to the junction box, verify that the turnstile control board is receiving approximately 10 VAC from the transformer.</p>
	The turnstile is not receiving an activation signal from the access control system.	<p>Ensure that the access control system is properly connected to the turnstile control board.</p> <p>Confirm that the access control system is providing a proper activation signal.</p>
	A lock arm spring is missing, broken or worn out.	<p>Replace the springs.</p> <p><b>NOTE:</b> The springs installed in the EDC turnstile are specifically designed for use in this application. Use only springs purchased from Alvarado. Turnstile springs are not interchangeable and should only be used in their designated locations. <b>See Spring Kit in Appendix B on Page 27.</b></p>
	The lock arm is sticking or binding in the locked position.	<p>Clean and lubricate the lock arms.</p> <p><b>If necessary adjust the hydraulic closure as described on Page 15.</b></p>
	The solenoid is defective.	<p>Test and replace the solenoid as necessary. <b>See Solenoid (12 VDC) Kit in Appendix B on Page 27.</b></p>
	The solenoid is de-energizing but the plunger is not “firing”.	<p>Adjust the solenoid plunger-limiting bracket. <b>See NOTE #2 on Page 20.</b></p>
	The turnstile control board is defective.	<p>Verify the green LED on the turnstile control board is illuminated. Verify the test activation buttons on the turnstile control board cause an activation when pressed. If either of these tests fail, replace the turnstile control board. <b>See Turnstile Control Board Kit in Appendix B on Page 28.</b></p>

Troubleshooting (cont.)

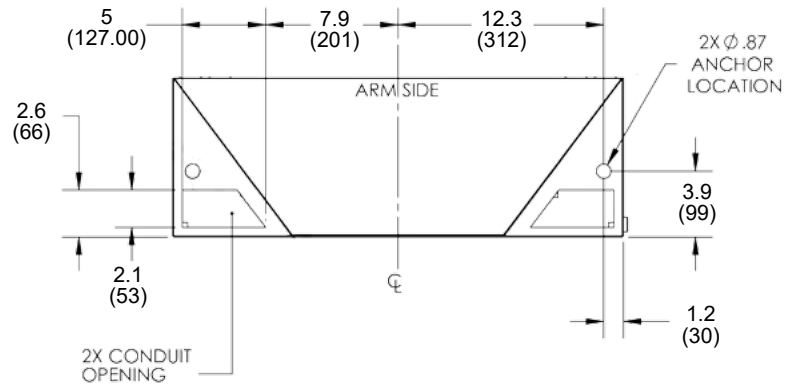
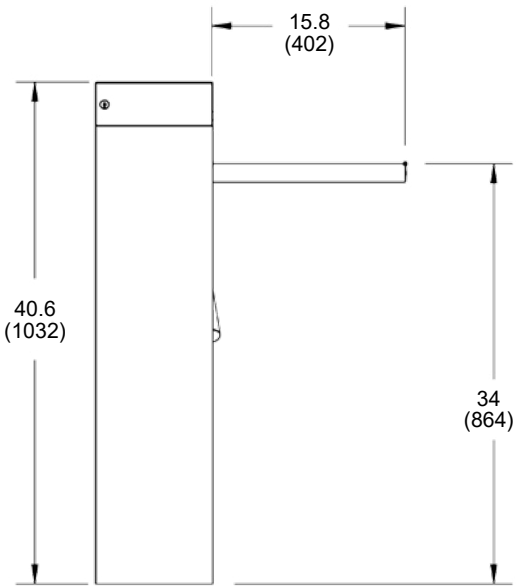
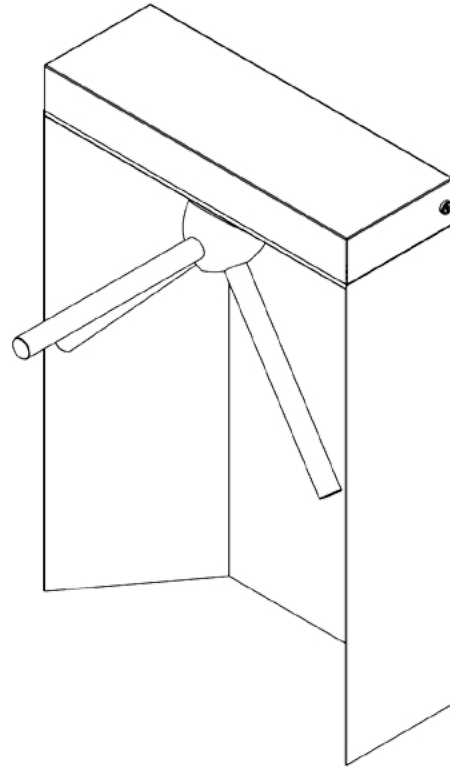
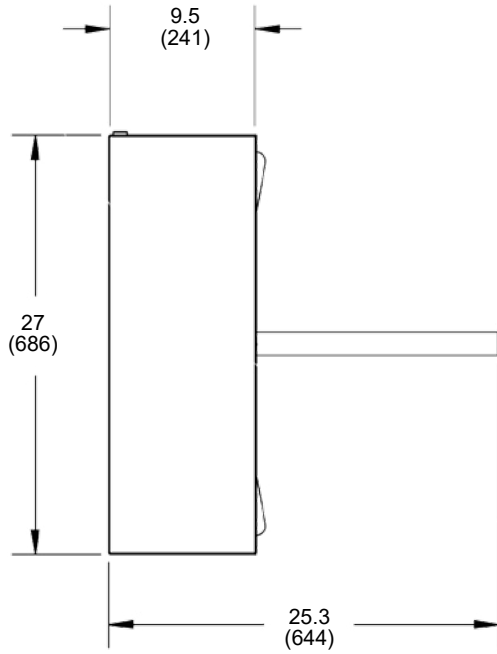
Symptom	Possible Cause	Solution
<b>Turnstile does not re-lock</b>	There is no power to the turnstile (Fail-Safe units only).	<p>Confirm that the ON/OFF switch is in the ON position.</p> <p>Confirm that the fuse is still good. If necessary replace the fuse.</p> <p>Confirm that the LED on the turnstile control board is on and not flickering [Figure 7]. If the LED on the turnstile control board is not lit, verify that proper voltage (110 -120VAC) is being provided to the junction box inside the turnstile. Do this by plugging in any device such as a light, drill, radio, etc.</p> <p>If the proper voltage (110-120VAC) is being provided to the junction box, verify that the turnstile control board is receiving approximately 10 VAC from the transformer.</p>
	The optical sensors are obstructed or misaligned.	<p>Remove any dirt or debris that may be obstructing the optical sensors.</p> <p>If necessary, tighten the optical sensor mounting screws so that the turnstile rotation tabs on the optical feedback disk pass through the sensors clearly.</p>
	The optical sensor is broken or not functioning properly.	Repair or replace the optical sensor assembly. <b>See Optical Sensor Assembly Kit in Appendix B on page 26.</b>
	A lock arm spring is missing, broken or worn out.	<p>Replace the springs. <b>See Spring Kit in Appendix B on Page 27.</b></p> <p><b>NOTE:</b> The springs installed in the EDC turnstile are specifically designed for use in this application. Use only springs purchased from Alvarado. Turnstile springs are not interchangeable and should only be used in their designated locations.</p>
	The solenoid is defective.	Test and replace the solenoid as necessary.
	The solenoid is de-energizing but the plunger is not "firing".	Adjust the solenoid plunger-limiting bracket. <b>See NOTE #2 on Page 20.</b>

**Troubleshooting (cont.)**

<i>Symptom</i>	<i>Possible Cause</i>	<i>Solution</i>
<b>The turnstile head does not turn smoothly.</b>	The turnstile is not properly lubricated.	Clean and lubricate the roller bearings as described in the Lubrication section on Page 16.  <b>If necessary adjust the hydraulic closure as described on Page 15.</b>
<b>The solenoid plunger is sticking.</b>	The solenoid is obstructed by foreign matter or debris.	Remove any dirt or debris that may be obstructing the solenoid or the plunger.
	The solenoid bracket is out of alignment.	Adjust the solenoid plunger-limiting bracket. <b>See NOTE #2 below.</b>

<i>Symptom</i>	<i>Possible Cause</i>	<i>Solution</i>
<b>The horizontal drop arm does not drop during loss of power or fire alarm input.</b>	The turnstile is not receiving an activation signal from the fire alarm / emergency override system.	Ensure that the fire alarm / emergency override system is properly connected to the turnstile control board.  Confirm that the fire alarm / emergency override system is providing a proper activation signal.
	The drop arm solenoid power wires are disconnected.	Check drop arm solenoid wires and reconnect as necessary.
	The drop arm solenoid is defective.	Test and replace the solenoid as necessary.
<b>The horizontal drop arm does not lock in the home position.</b>	Lock arm mechanism is faulty.	Contact Alvarado Technical Support for assistance.

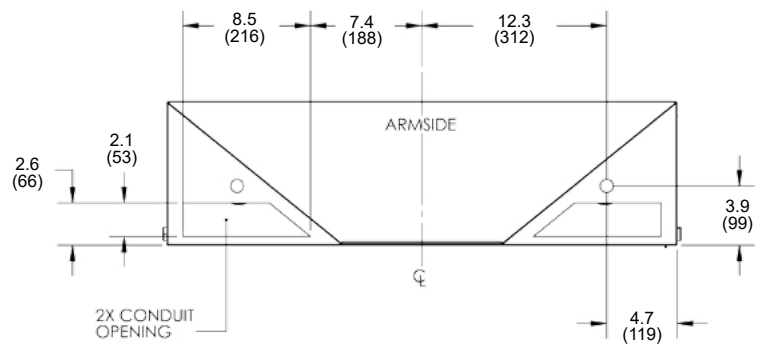
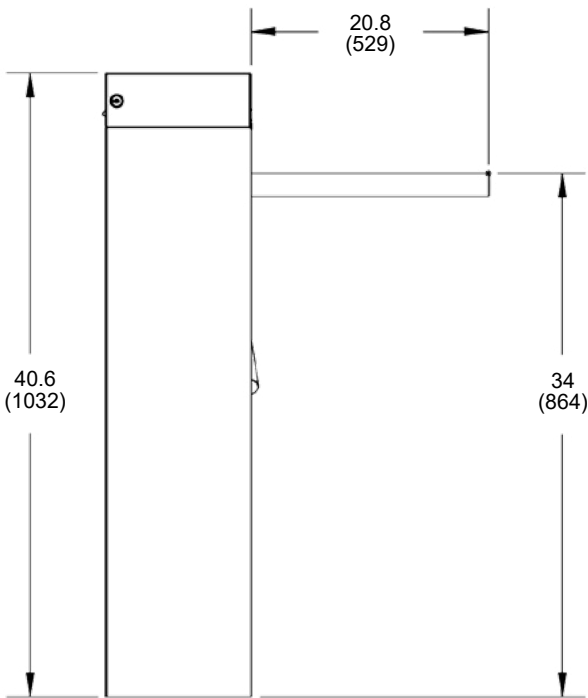
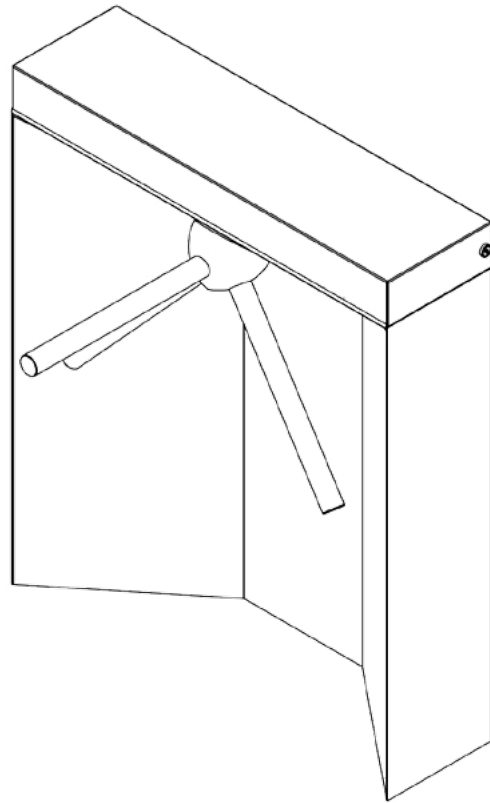
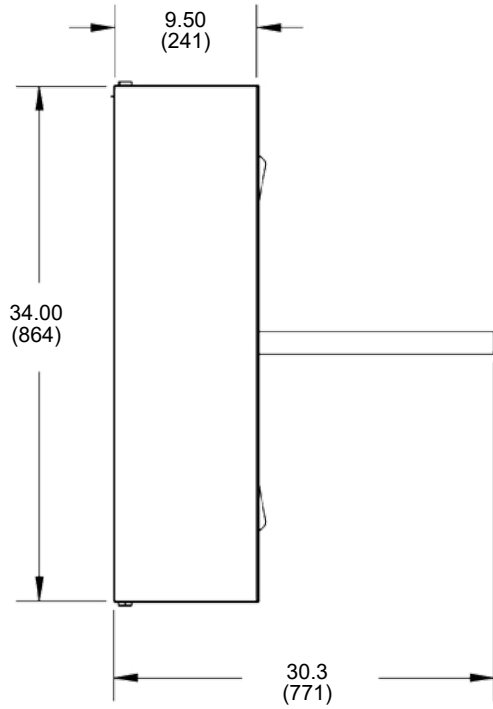
Appendix A - Plan, Elevation and Footprint Drawings  
EDC (27" Length)



**NOTE** ALL DIMENSIONS ARE APPROXIMATE

Appendix A - Plan, Elevation and Footprint Drawings (cont.)

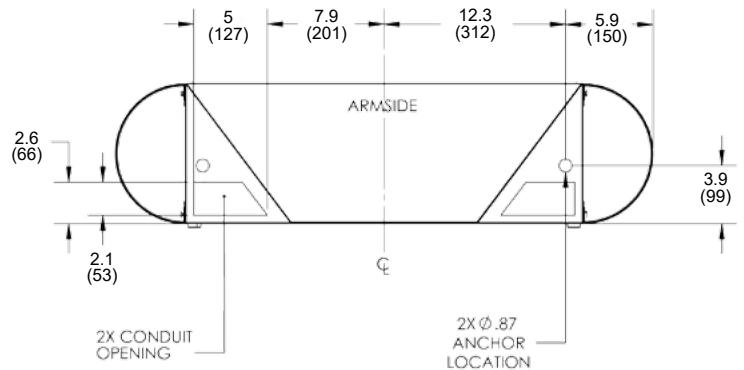
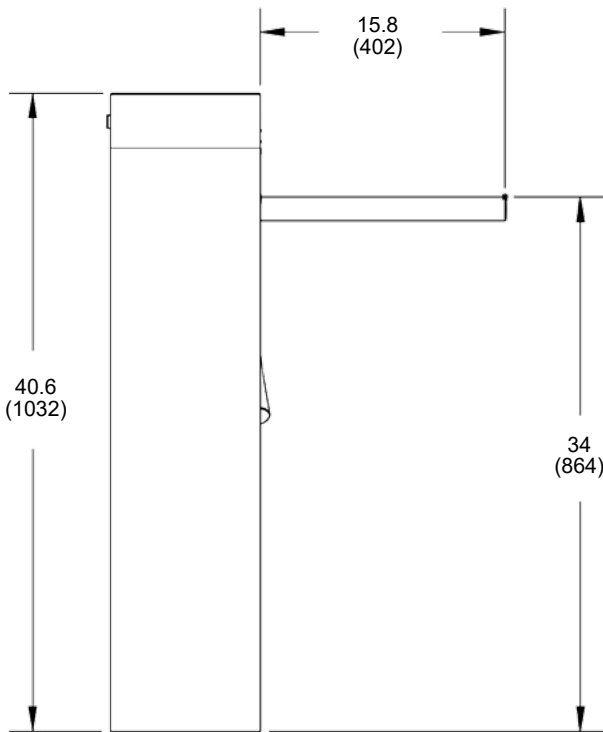
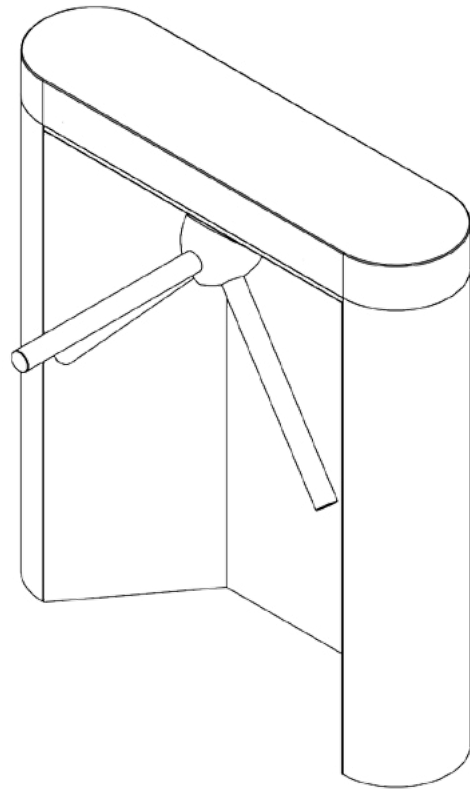
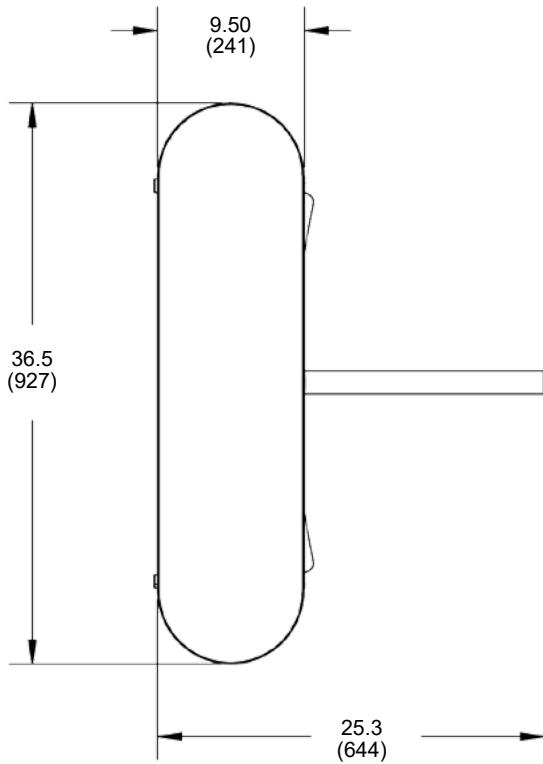
EDC-E (Extended)



**NOTE** ALL DIMENSIONS ARE APPROXIMATE

Appendix A - Plan, Elevation and Footprint Drawings (cont.)

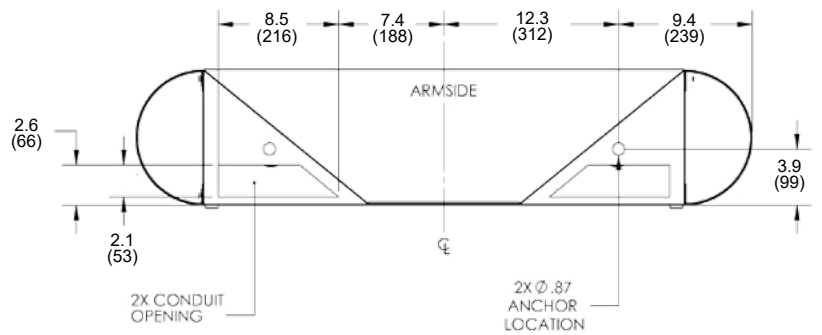
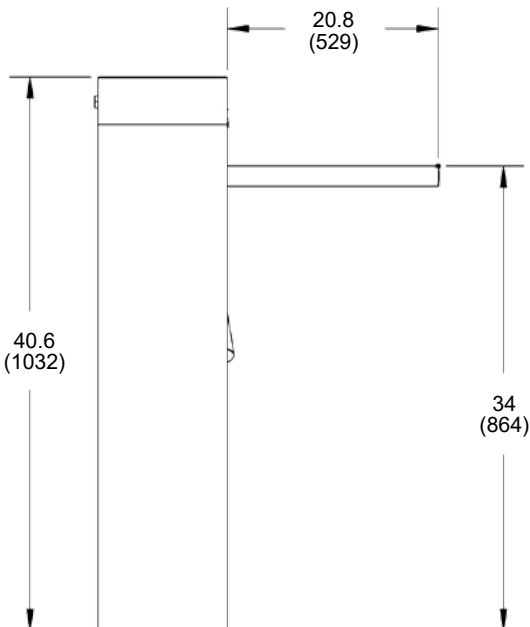
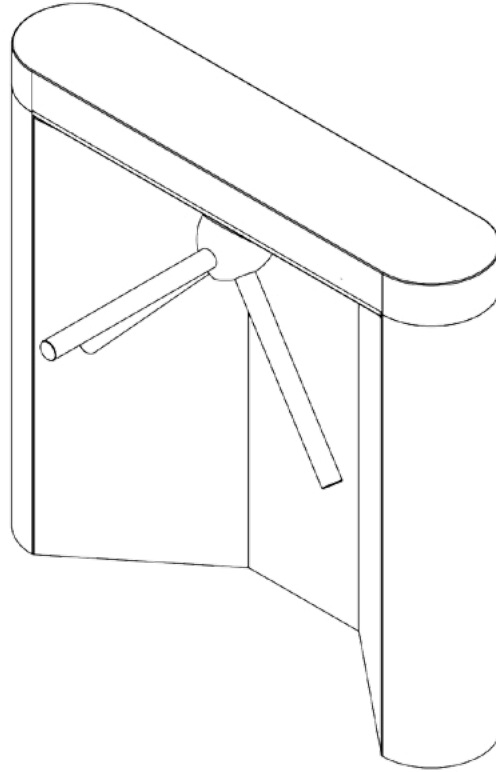
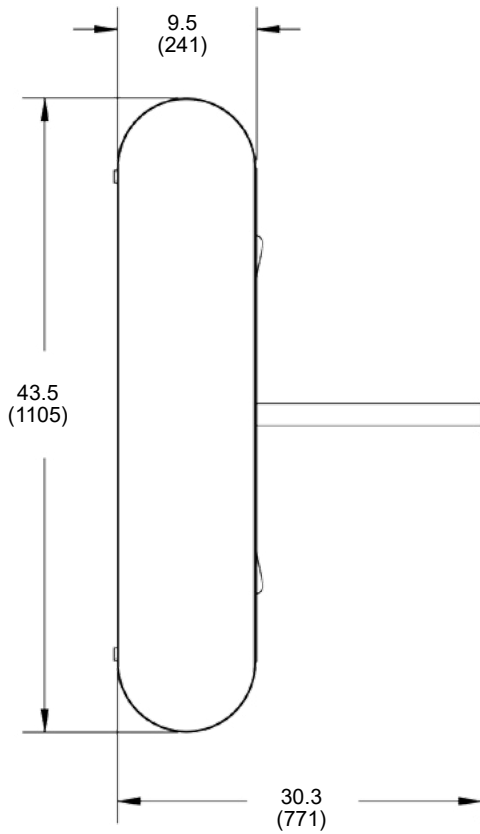
EDC-BN (Bullnose)



**NOTE** ALL DIMENSIONS ARE APPROXIMATE

Appendix A - Plan, Elevation and Footprint Drawings (cont.)

EDC-EBN (Extended Bullnose)



**NOTE**

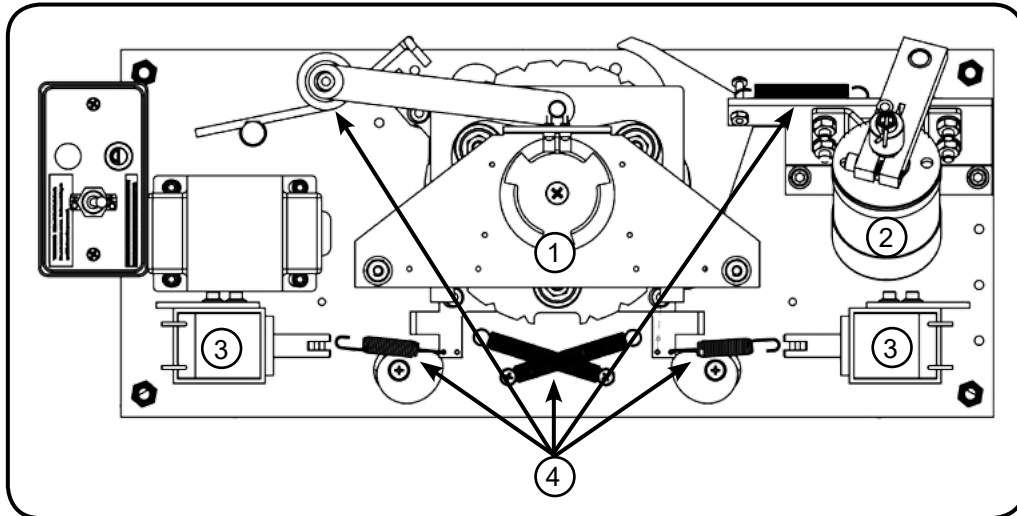
ALL DIMENSIONS ARE APPROXIMATE



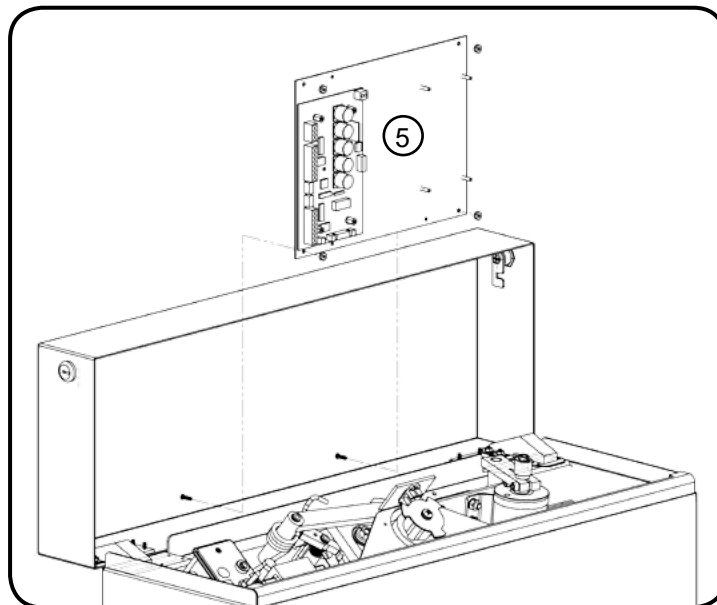
**Appendix B - Replacement Parts Kits**

Below are the most commonly used replacement parts kits for EDC turnstiles. Additional parts kits are available. Contact Alvarado Technical support at (909) 591-8431 for assistance.

**Fig. B1** Kit Locations - EDC Sub Assembly



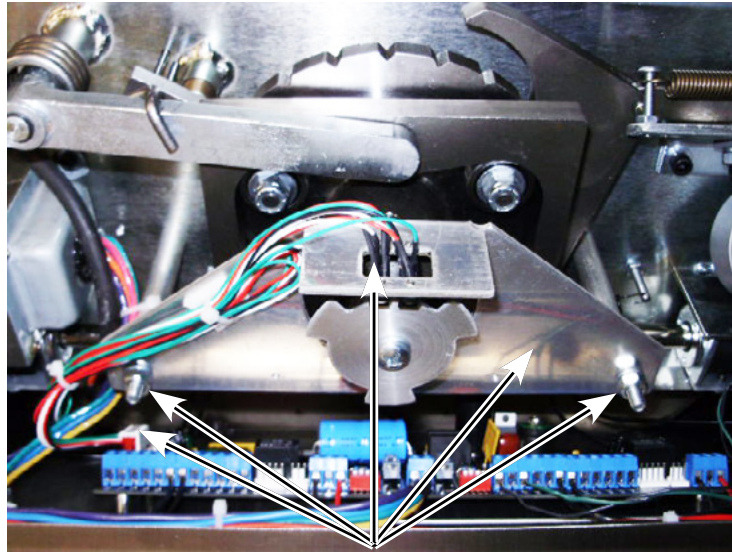
**Fig. B2** Kit Locations - EDC Cabinet



**EDC Replacement Parts Kits**

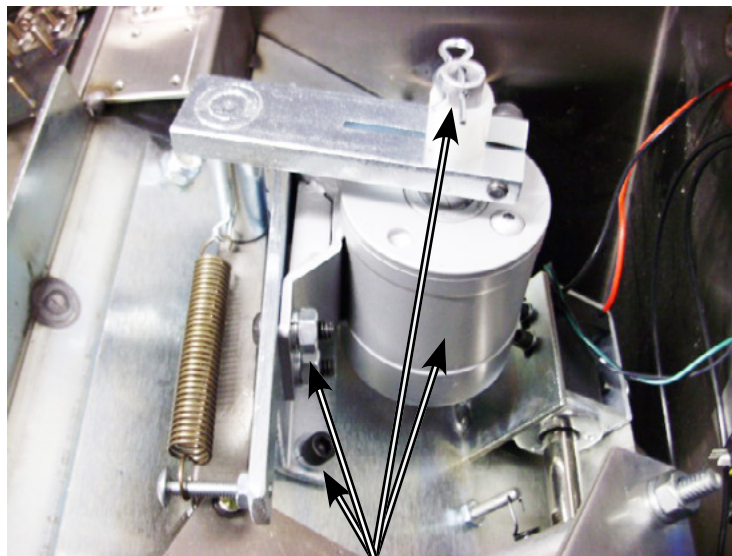
ITEM	DESCRIPTION	KIT P/N	FIGURE
1	Optical Sensor Assembly Kit	50-04-7380A	B1
2	Hydraulic Closure Kit	50-11-9060	B1
3	Solenoid (12 VDC) Kit	50-10-1070	B1
4	Spring Kit	50-EDC-S1	B1
5	Turnstile Control Board Kit	50-10-7821	B2

Appendix B - Replacement Parts Kits (cont.)



**Optical Sensor Assembly Kit (Kit P/N 50-04-7380A)**

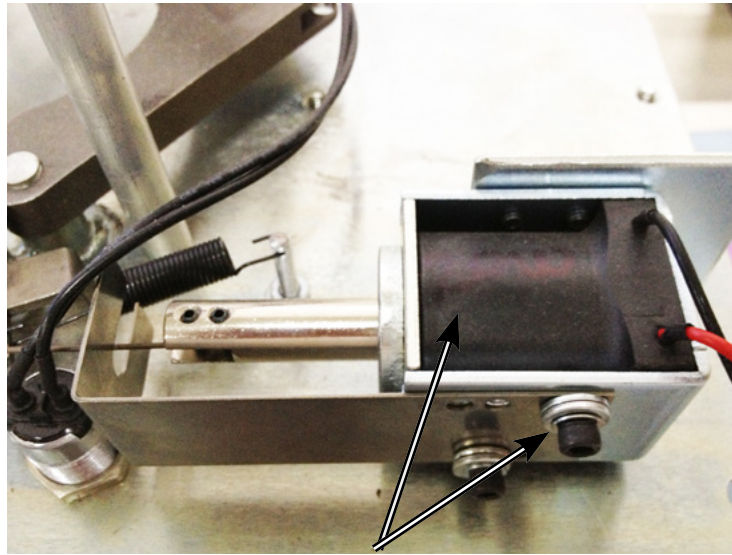
DESCRIPTION	QTY
Optical Sensor Assembly (includes wire harness)	1
1/4"-20 Hex Nut - Zinc	2
1/4" Flat Washer	2
1/4" Spit Lockwasher - Zinc	2



**Hydraulic Closure Kit (Kit P/N 50-11-9060)**

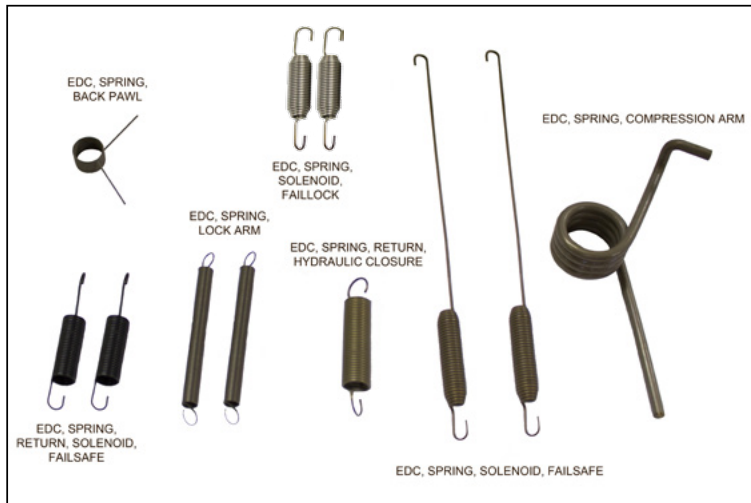
DESCRIPTION	QTY
Compressor Arm Spring	1
Hydraulic Closure Unit	1
Closure Unit Spacer	1
1/4"-20 x 5/8" Socket Head Cap Screw - Blk Oxide	2
1/4"-20 x 3/4" Button Head Socket Cap Screw - Blk Oxide	4
1/4"-20 Hex Nut - Zinc	4
1/4" Split Lockwasher - Zinc	6

Appendix B - Replacement Parts Kits (cont.)



**Solenoid (12VDC) Kit (Kit P/N 50-10-1070)**

DESCRIPTION	QTY
Solenoid 12V, w/ Plunger	2
8-32 x 1/4" Socket Head Cap Screws - Blk Oxide	4
8-32 x 5/16" Socket Head Cap Screws - Blk Oxide	2
#8 Lock Washer, Internal Tooth - Zinc	12
#8 Flat Washer - Zinc	8

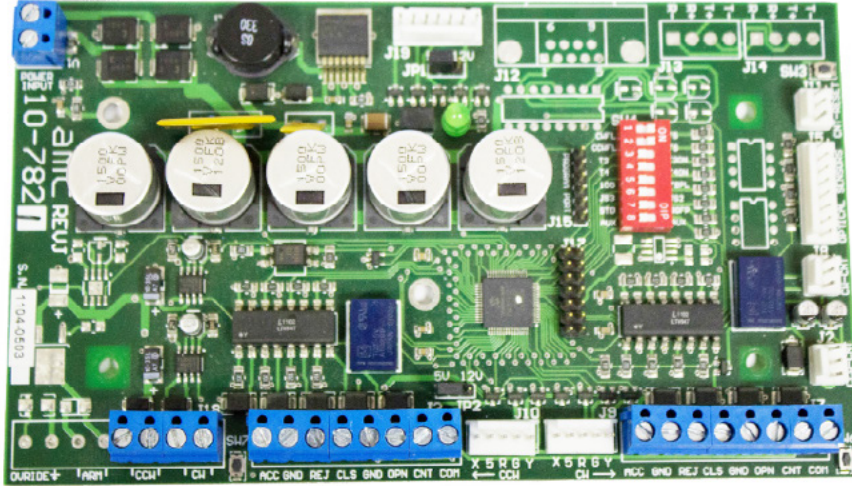


**Spring Kit (Kit P/N 50-EDC-S1)**

DESCRIPTION	QTY
Compression Arm Spring	1
Back Pawl Spring	1
Solenoid Spring (for Fail-Safe only)	2
Solenoid Return Spring (for Fail-Safe only)	2
Lock Arm Spring	2
Hydraulic Closure Return Spring	1
Solenoid Spring (for Fail-Lock only)	2

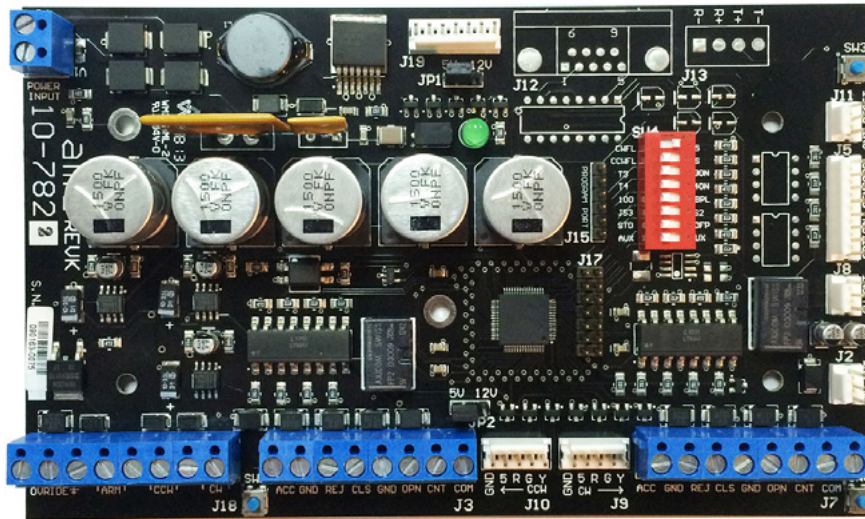


Appendix B - Replacement Parts Kits (cont.)



**Turnstile Control Board (Kit P/N 50-10-7821)**

DESCRIPTION	QTY
10-7821 Turnstile Control Board	1
Dry Contact Label	1
6-32 x 1/4" Round Head Phillips Screw - Zinc	4
6-32 x 3/8" Standoff, F/F - Aluminum	4
Disposable Grounding Strap	1

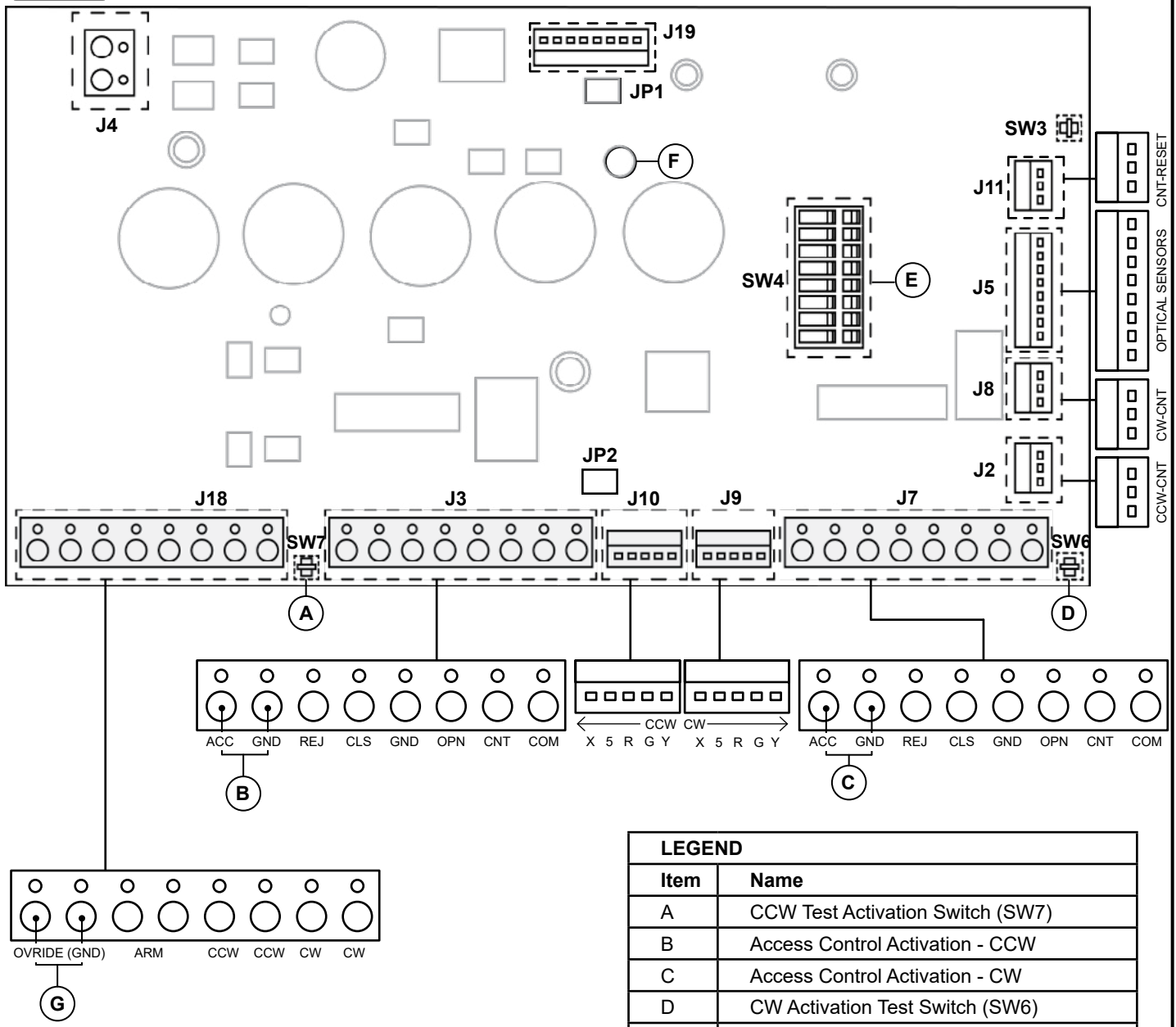


**Turnstile Control Board (Kit P/N 50-10-7822)  
[Drop-Arm Option]**

DESCRIPTION	QTY
10-7822 Turnstile Control Board	1
Dry Contact Label	1
6-32 x 1/4" Round Head Phillips Screw - Zinc	4
6-32 x 3/8" Standoff, F/F - Aluminum	4
Disposable Grounding Strap	1

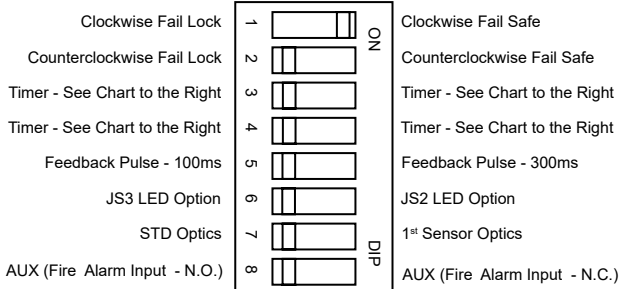
Appendix C - 10-7822 Turnstile Control Board Layout and Terminal Descriptions

Fig. C1 10-7822 Turnstile Control Board



LEGEND	
Item	Name
A	CCW Test Activation Switch (SW7)
B	Access Control Activation - CCW
C	Access Control Activation - CW
D	CW Activation Test Switch (SW6)
E	DIP Switches (SW4)
F	Green LED
G	Drop-Arm Fire Alarm System / Solenoid Connection

Fig. C1a SW4 Layout



**NOTE**

Default DIP switch settings pictured above are for Fail-lock/Fail-safe configurations.

Fig. C1b Automatic Turnstile Relock Setting Switches

Automatic turnstile relock Setting (Positions T3 and T4)	T3	T4
5 seconds	ON	ON
10 seconds	ON	OFF
15 seconds	OFF	ON
20 seconds (Default)	OFF	OFF

**Appendix C - 10-7822 Turnstile Control Board Layout (cont.)**

BOARD	NAME	DESCRIPTION	EXPLANATION
J18	ARM	Solenoid VDC wire connection - Drop Arm	Connection for drop arm solenoid. Universal polarity.
J18	ARM	Solenoid VDC wire connection - Drop Arm	Connection for drop arm solenoid. Universal polarity.
J18	OVERRIDE	Emergency Override control wire connection	This terminal is used to connect the emergency override / fire alarm system signal. <u>This input is used for drop arm option only.</u>
J18	(GND)	Emergency Override ground wire connection	Ground wire connection for "OVERRIDE" input.
J18	CCW	Solenoid VDC wire connection - CCW Direction	Connection for counterclockwise solenoid. Universal polarity.
J18	CCW	Solenoid VDC wire connection - CCW Direction	Connection for counterclockwise Solenoid. Universal polarity.
J18	CW	Solenoid VDC wire connection - CW Direction	Connection for clockwise solenoid. Universal polarity.
J18	CW	Solenoid VDC wire connection - CW Direction	Connection for clockwise solenoid. Universal polarity.
SW7	CCW Entry Activation Test Button	Allows user to test turnstile activation - CCW Direction	Depressing button simulates input to J3 ACC, "Entry Accept". If turnstile solenoid "fires" after depressing button AND re-locks after a single rotation of the arms or upon time out, the turnstile is functioning correctly in the counterclockwise direction.
J3	ACC Entry Accept	"Card Authorized" input connection from the access control system - CCW Direction	This connection is used to tell the turnstile to unlock. The turnstile control board will accept a normally-open dry-contact signal of .5 seconds to 1 second from the access control system and allow one rotation of the arms before re-locking.
J3	GND Ground	Ground wire connection from the access control system - CCW Direction	Ground wire connection position for ACC and REJ contact signal.
J3	REJ Entry Reject	"Card Reject" input connection from the access control system - CCW Direction	This connection is used to tell the turnstile to remain locked. The access control system has determined that the card presented is unauthorized for entry.
J3	CLS Close Passage	Connection for placing turnstile in locked "CLOSED" status - CCW Direction	Providing a continuous dry-contact signal at this terminal places the turnstile in a locked "CLOSED" mode. This mode overrides the access control system operation. If status lights are installed (Location J19) the red light will be illuminated continuously.
J3	GND Ground	Ground wire connection for "OPN/CLS" lane control - CCW Direction	Ground wire connection for "OPN/CLS" passage control.
J3	OPN Open Passage	Connection for placing turnstile in "OPEN" status - CCW Direction	Providing a continuous dry-contact signal at this terminal places the turnstile in an "OPEN" mode. Typically, this terminal is used to connect the fire alarm system when the turnstile is configured for counterclockwise rotation in the exit direction. <u>DO NOT use this input if the drop arm option is installed; use the OVERRIDE input instead.</u>
J3	CNT Passage Count	Confirmation signal upon turnstile rotation - CCW Direction	Outputs a dry contact upon rotation of the turnstile. This feature can be used to output a "count" signal to an external system such as Alvarado's GateWatch or to provide feedback to the access control system that a turnstile rotation has taken place.
J3	COM Passage Count	Confirmation signal upon turnstile rotation - CCW Direction	Common dry contact connection for CNT count signal output. See J3 CNT description.
J10	X5RGY-CCW	Connection for Activation Lights - CCW Direction	Connection for JS2 and JS3 activation lights.
J9	X5RGY-CW	Connection for Activation Lights - CW Direction	Connection for JS2 and JS3 activation lights.
J7	ACC Entry Accept	"Card Authorized" input connection from the access control system - CW Direction	This connection is used to tell the turnstile to unlock. The turnstile control board will accept a normally-open dry-contact signal of .5 seconds to 1 second from the access control system and allow one rotation of the arms before re-locking.
J7	GND Ground	Ground wire connection from the access control system - CW Direction	Ground wire connection position for ACC and REJ contact signal.
J7	REJ Entry Reject	"Card Reject" input connection from the access control system - CW Direction	This connection is used to tell the turnstile to remain locked. The access control system has determined that the card presented is unauthorized for entry.

**Appendix C - 10-7822 Turnstile Control Board Layout (cont.)**

J7	GND Ground	Ground wire connection for "OPN/CLS" lane control - CW Direction	Ground wire connection for "OPN/CLS" passage control.
J7	CLS Close Passage	Connection for placing turnstile in "OPEN" status - CW Direction	Providing a continuous dry contact at this terminal places the turnstile in a locked "CLOSED" mode. This mode overrides the access control system operation. If status lights are installed (Location J19) the red light will be illuminated continuously.
J7	OPN Open Passage	Connection for placing turnstile in "OPEN" status - CW Direction	Providing a continuous dry-contact signal at this terminal places the turnstile in an "OPEN" mode. Typically, this terminal is used to connect the fire alarm system when the turnstile is configured for clockwise rotation in the exit direction. <u>DO NOT use this input if the drop arm option is installed; use the OVRIDE input instead.</u>
J7	CNT Passage Count	Confirmation signal upon turnstile rotation - CW Direction	Outputs a dry contact upon rotation of the turnstile. This feature can be used to output a "count" signal to an external system such as Alvarado's GateWatch or to provide feedback to the access control system that a turnstile rotation has taken place.
J7	COM Passage Count	Confirmation signal upon turnstile rotation - CW Direction	Common dry contact connection for CNT count signal output. See J7 CNT description.

**Revision History**

Revision	Date	Author	Description
5-2	04/02/15	A. Flores	Updated junction box figures. Revised maintenance instructions.
5-3	10/13/15	A. Flores	Revised product dimensions.
5-4	01/08/16	A. Flores	Revised product dimensions.  SW4 DIP switch 8 configures OPN inputs as either normally open (N.O.) or normally closed (N.C.).
5-5	02/19/16	A. Flores	Added drop-arm functionality.



This page intentionally left blank.



**Alvarado Manufacturing Company, Inc.**